

**COLTRI**  
THE ITALIAN COMPRESSOR

# Catalogue Filling stations

Breathing air

dystrybutor oraz autoryzowany serwis:

**SCUBA MISSION**  
Rafał Kowalewski

ul. Mazurska 7  
70-424 Szczecin - Poland

tel +48 91 4881787  
fax +48 91 4881787

[www.scubamission.pl](http://www.scubamission.pl)  
[info@scubamission.pl](mailto:info@scubamission.pl)



High pressure compressors  
for breathing air and technical gases

We build quality.  
Made in Italy.



A profoundly Italian company, Coltri began building high-pressure scuba diving compressors in 1963. The company soon expanded into other fields, including firefighting compressors and industrial gas compressors. Today we are once again looking in a new direction.

Ongoing advances in design and manufacture are at the very core of our identity: more than fifty years of continuous development have enabled us to engineer equipment that now sets the benchmark for the industry worldwide.

Our commitment to research and development has enabled us to shift from consuming the latest technology to becoming key players ourselves in advancing technology in the industry. We use all the latest tools, such as robots and digitally controlled machining centers, to manufacture increasingly reliable, efficient and durable products.

Every component in our pump units was designed and engineered in Coltri's workshops and is the result of careful research and extensive testing. We assemble all our compressors in their entirety within our company according to rigorous quality standards. Exceptionally high-precision machinery, such as ZEISS® tools, play a key role in dimensional metrology. This enables us to determine the geometric characteristics of our components and accurately gauge how they will perform when used in more complex units.

Our focus and constant growth, steered by standards of excellence, have earned us internationally recognized certifications of quality that reflect our dedication and commitment.

We like to think of ourselves as facilitators. We build our machines to make it simpler to take on challenges, overcome limits and imagine new possibilities. Whether it's for a hobby, an industrial application or an emergency response service, Coltri Compressors is there to raise the bar higher, to help you reach uncharted territory.



Discover our construction quality.  
Scan the QR code to watch the video.



# Application

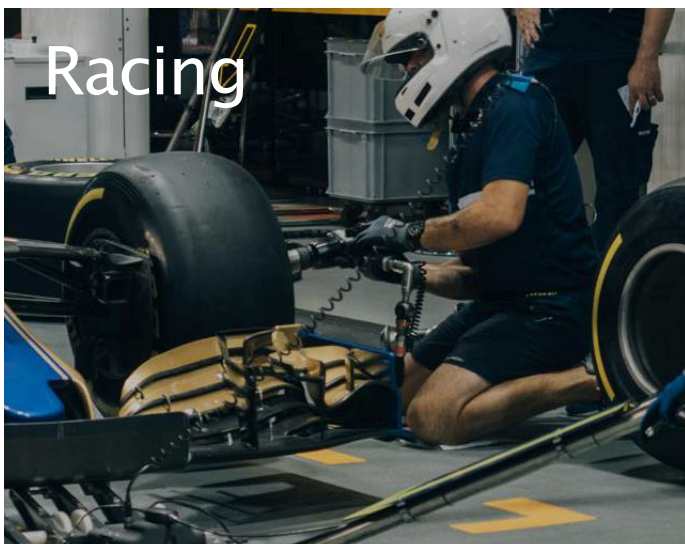
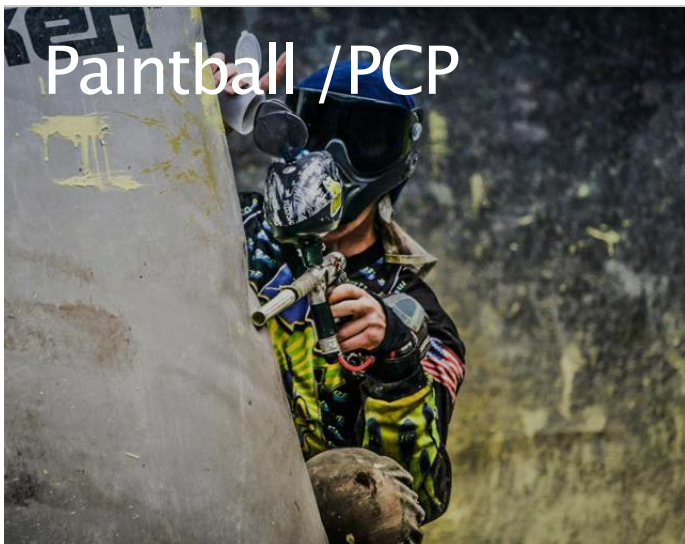

# Research, development, production and assembly take place in the 8,000 square meters of the headquarters thanks to our human value.

From Desenzano del Garda, the Company is a byword for Made In Italy quality, reaching 130 countries around the world every day. Research, development, production and assembly in our 8000m<sup>2</sup> plant revolve around the “Coltri human value”: over 50 technicians committed to overcoming new challenges in performance, silence, durability, and innovation. To meet these challenges, the company uses the most advanced instruments, including robots and

numerically controlled machine tools, to create products that are ever more reliable, efficient and effective.

To ensure our after-sales service is on a par with our product line, customers can avail of our a spare parts warehouse for ordinary and extraordinary maintenance, and courtesy compressors to cover any contingency.





# When choosing your Coltri compressor, begin with performance.

## Charging rate (l/min.)

Mini Silent Pumping units: 100-125	100 – 125 l/min							
Smart Pumping units: 125-210-235-270-315	125 – 315 l/min							
Mark III Silent Pumping units: 210-235-270-315-330	210 – 330 l/min							
Ergo Pumping units: 210-235-270-285-315	210 – 315 l/min							
Super Silent Pumping units: 235-315-330	235 – 330 l/min							
Mark III Silent TPS Pumping units: 210-235-270-315-345-380TPS	210 – 380 l/min							
Ergo TPS Pumping units: 235-270-315-345-380TPS	235 – 380 l/min							
Super Silent TPS Pumping units: 235-270-315-345-380TPS	235 – 380 l/min							
Open Pumping units: 450-550-650-750					450 – 750 l/min			
Silent Pumping units: 450-550-650-750					450 – 750 l/min			
Pumping units charging rate (l/min)	0	100	200	300	400	500	600	700

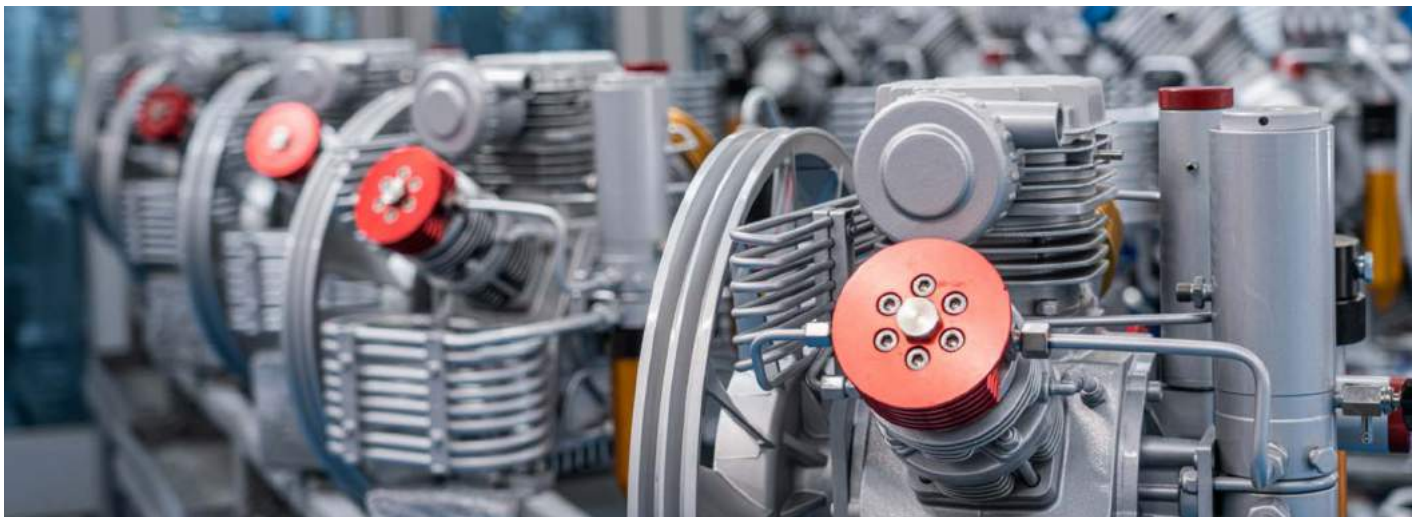

# How many cylinders do you want to refill in 1 hour?

Measurement carried out on empty 15-litre cylinders -0/200 bar at 20° C (tolerance ±5%)

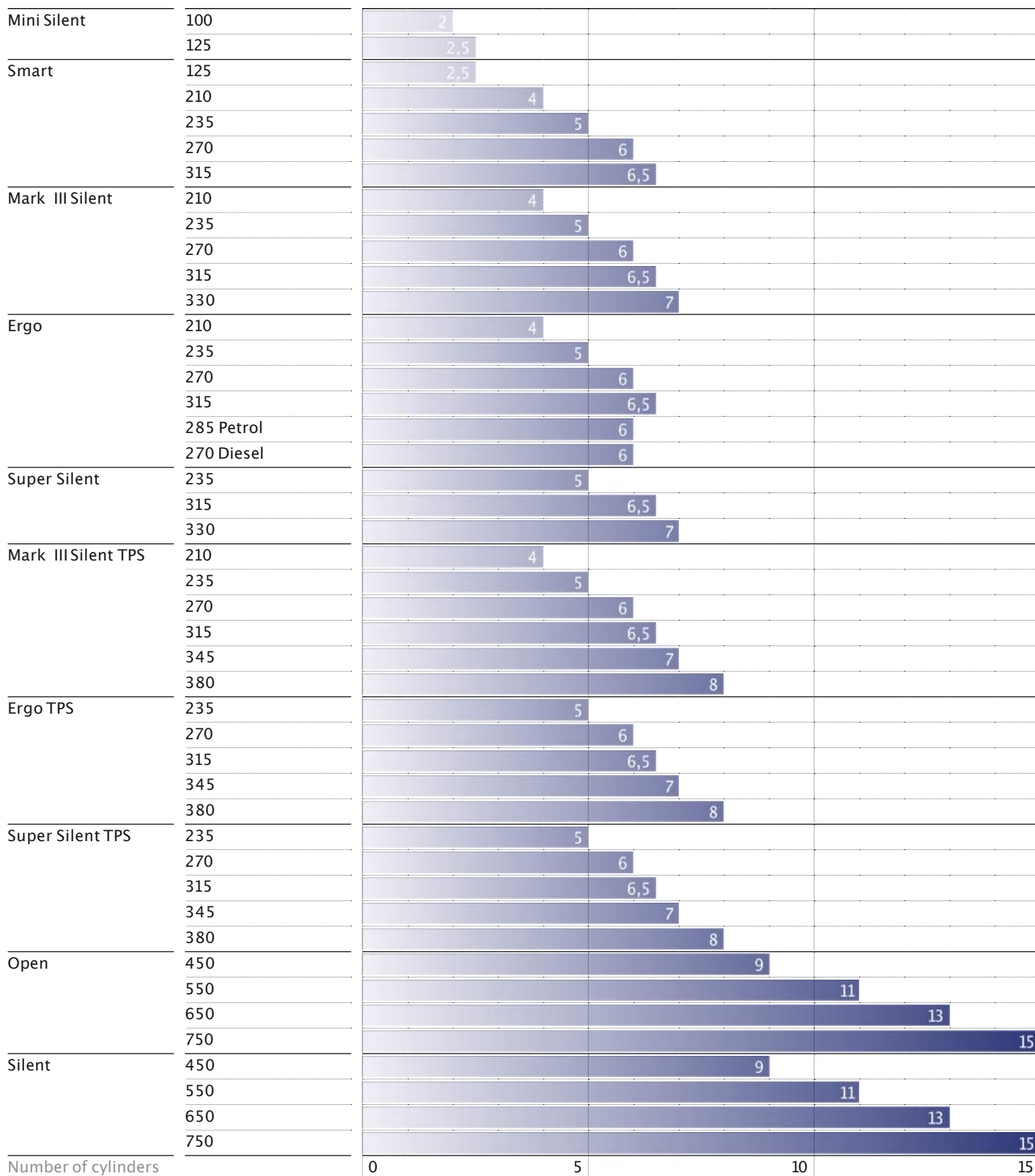

# Compare models and learn more about the right product for you.

LINE / COMPRESSOR	L/MIN	RPM	NOISE LEVEL LPA - DB	DIMENSIONS (W X D X H) CM - IN	FILTERS DURATION PURIFICATION VOL. AIR M <sup>3</sup> *	POWER KW - HP
<b>EFFICIENT LINE</b>						
Mark III Silent235 Pag. 18	235	1270	63	130x730x91 40.5x28.7x35.8	296 cylinders	4 - 5.5
Mark III Silent315 Pag. 18	315	1600	65	90 x 91 x 132 35.4 x 35.8 x 52	296 cylinders	5,5 - 7.5
Ergo 235 Pag. 22	235	1240	72	63 x 112x 77 24.8 x 44.1 x 30.3	296 cylinders	4 - 5.5
Ergo 315 Pag. 22	315	1600	72	63 x 112x 77 24.8 x 44.1 x 30.3	296 cylinders	5,5 - 7.5
<b>PRIME LINE</b>						
Mark III SilentTPS 235 Pag. 34	235	1240	72	93,5 x 130 x 173 35.4 x 36.6 x 52	1.016cylinders	4 - 5.5
Mark III SilentTPS 315 Pag. 34	315	1600	72	93,5 x 130 x 173 35.4 x 36.6 x 52	1.016cylinders	5,5 - 7.5
Mark III SilentTPS 345 Pag. 34	345	1240	72	93,5 x 130 x 173 35.4 x 36.6 x 52	1.016cylinders	7,5 - 10
Mark III SilentTPS 380 Pag. 34	380	1400	72	93,5 x 130 x 173 35.4 x 36.6 x 52	1.016cylinders	7,5 - 10
Ergo TPS 235 Pag. 38	235	1240	72	63 x 112x 77 24.8 x 44.1 x 30.3	1.016cylinders	4 - 5.5
Ergo TPS 315 Pag. 38	315	1600	72	63 x 112x 77 24.8 x 44.1 x 30.3	1.016cylinders	5,5 - 7.5
Ergo TPS 345 Pag. 38	345	1240	72	63 x 112x 77 24.8 x 44.1 x 30.3	1.016cylinders	7,5 - 10
Ergo TPS 380 Pag. 38	380	1400	72	63 x 112x 77 24.8 x 44.1 x 30.3	1.016cylinders	7,5 - 10
<b>HEAVY DUTY LINE</b>						
Open 450 Pag. 46	450	1050	72	90,5 x 105 x 153 35.6 x 41.4 x 60.2	1.016cylinders	7,5 - 10
Open 550 Pag. 46	550	1250	72	90,5 x 105 x 153 35.6 x 41.4 x 60.2	1.016cylinders	9 - 12,5
Open 650 Pag. 46	650	1250	72	90,5 x 105 x 153 35.6 x 41.4 x 60.2	1.016cylinders	11 - 15
Open 750 Pag. 46	750	1420	72	90,5 x 105 x 153 35.6 x 41.4 x 60.2	1.016cylinders	15 - 20

\* Value calculated on the refilling of an empty 15-liter cylinder, at 300 bar, at a temperature of +20°C (tolerance +/-5%).



LINE / COMPRESSOR	L/MIN	RPM	NOISE LEVEL LPA - DB	DIMENSIONS (W X D X H) CM - IN	FILTERS DURATION PURIFICATION VOL. AIR M <sup>3</sup> *	POWER KW - HP
<b>EFFICIENT LINE</b>						
Super Silent 235 Pag. 30	235	1270	63	90 x 91 x 132 35.4 x 35.8 x 52	296 cylinders	4 - 5.5
Super Silent 315 Pag. 30	315	1600	65	90 x 91 x 132 35.4 x 35.8 x 52	296 cylinders	5,5 - 7.5
Super Silent 330 Pag. 30	330	1660	65	90 x 91 x 132 35.4 x 35.8 x 52	296 cylinders	7,5 - 10
<b>PRIME LINE</b>						
Super Silent TPS 235 Pag. 42	235	1240	63	93,5 x 130 x 173 35.4 x 36.6 x 52	1.016cylinders	4 - 5.5
Super Silent TPS 315 Pag. 42	315	1600	65	93,5 x 130 x 173 35.4 x 36.6 x 52	1.016cylinders	5,5 - 7.5
Super Silent TPS 345 Pag. 42	345	1240	65	93,5 x 130 x 173 35.4 x 36.6 x 52	1.016cylinders	7,5 - 10
Super Silent TPS 380 Pag. 42	380	1400	65	93,5 x 130 x 173 35.4 x 36.6 x 52	1.016cylinders	7,5 - 10
<b>HEAVY DUTY LINE</b>						
Silent 450 Pag. 50	450	1050	67	93,5 x 130 x 173 36.8 x 51.3 x 68.3	1.016cylinders	7,5 - 10
Silent 550 Pag. 50	550	1250	67	93,5 x 130 x 173 36.8 x 51.3 x 68.3	1.016cylinders	9 - 12,5
Silent 650 Pag. 50	650	1250	67	93,5 x 130 x 173 36.8 x 51.3 x 68.3	1.016cylinders	11 - 15
Silent 750 Pag. 50	750	1420	67	93,5 x 130 x 173 36.8 x 51.3 x 68.3	1.016cylinders	15 - 20

\* Value calculated on the refilling of an empty 15-liter cylinder, at 300 bar, at a temperature of +20°C (tolerance +/-5%).

Efficient line

# Mini Silent

Electric



Mini Silent 100EM

Mini Silent 100ET

Mini Silent 125EM

Mini Silent 125ET

Charging rate

100 l/min

125 l/min

Refill time<sup>1</sup>

23 min

20 min

16 min

16 min

Engine power

2,2 kW

Single-phase electric

3 kW

Three-phase electric

3 kW

Single-phase electric

3 kW

Three-phase electric

<sup>1</sup> Filling time 10l empty cylinder -0/200 bar (tolerance ±5%)

Coltri's breathing air compressors of the Mini SILENT series, equipped with 100 and 125l/min pumping units, are characterized by extreme silence, obtained without sacrificing performance. The large space offered by the frame allows the use of a filtering system with Maxifilter. These compressors are available with single-phase or three-phase electric motor and integrated control panel with hour meter, they have automatic condensate drain and autostop as standard. The equipment includes a filling connection for flexible hose with working pressure from 232 to 330 bar.

## Working pressure from 232 to 330 bar

### Standard equipment

1	1 filling connection to choose between (1a) DIN 232, (1b) DIN 300 o (1c) INT/YOKE 232 bar	5	Autostop
2	1 filling hose of 1.2 m length	6	Maxifilter filtration system
3	Hour Meter	7	Auto-drain Condensate System with condensate collection tank
4	Pressure maintaining valve	8	Frame color RAL 7035 + RAL 6018

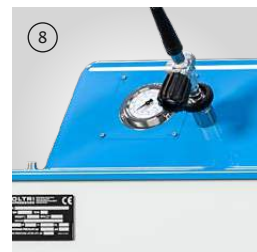
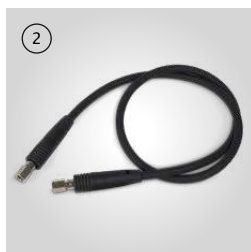

## Optional

- |   |  |   |  |
|---|--|---|--|
| 1 | C-Monitor                                | 5 | Filling connection with gauge QR 300 bar |
| 2 | Filling connection QR 232 bar            | 6 | DIN/INT adapter                          |
| 3 | Filling connection QR 300 bar            | 7 | Filling connection QR/INT                |
| 4 | Filling connection with gauge QR 232 bar | 8 | Filling hose. Available: 2 m – 3 m       |

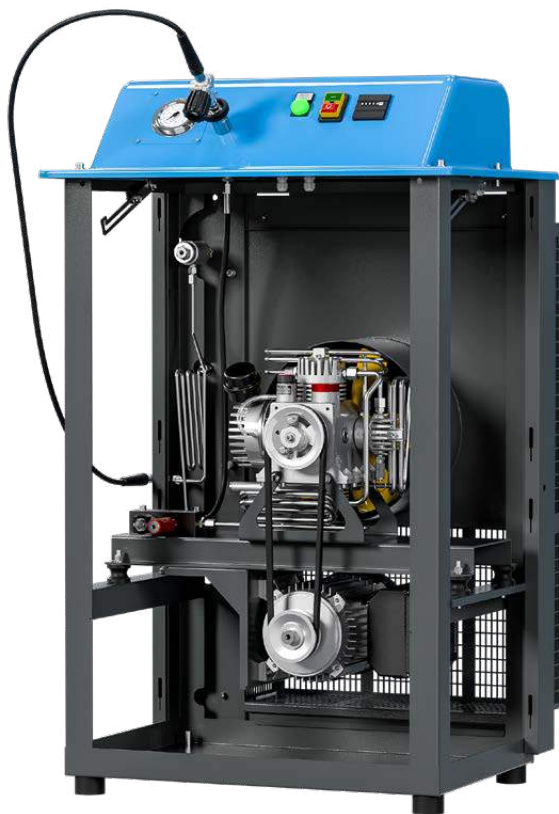
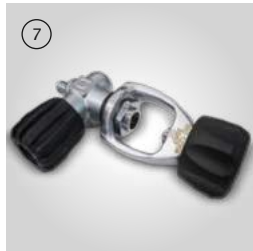

Mini Silent 100 EM

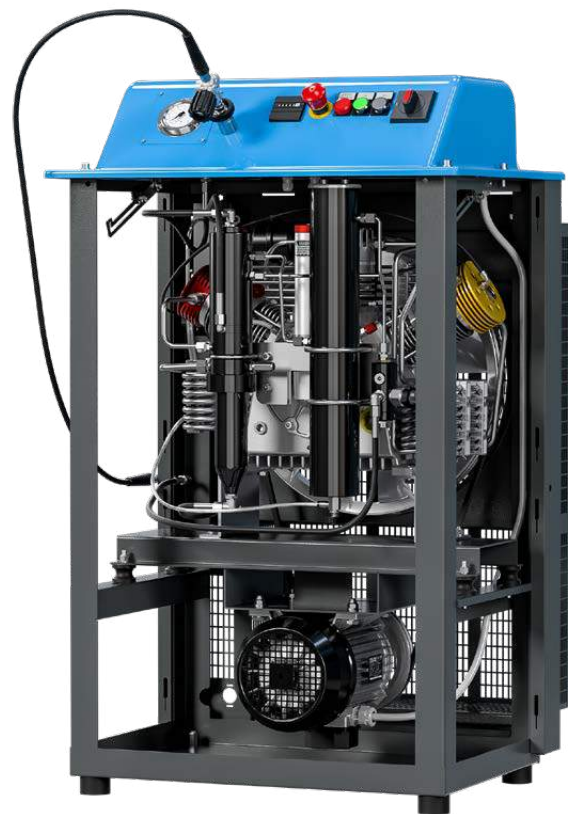

Mini Silent 125 ET



## Dimensions

Width 71,5 cm (28,1")

Depth 67 cm (26.4")

Height 110cm (43.3")

## Dry weight

MINI SILENT 100 EM

84,5 kg (186 lb)

MINI SILENT 100 ET

105 kg (231 lb)

MINI SILENT 125EM

84,5 kg (186 lb)

MINI SILENT 125ET

105 kg (231 lb)

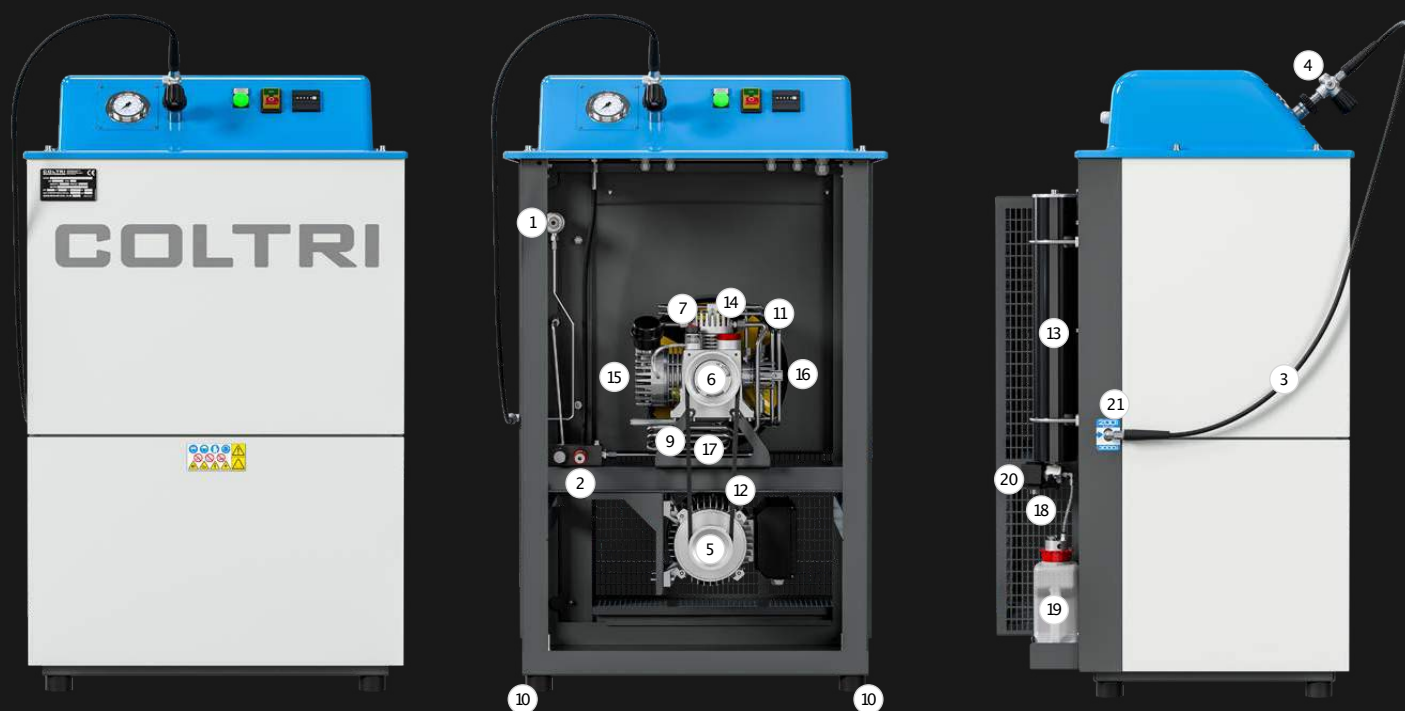

## Machine parts

- |                           |                                   |                                    |
|---------------------------|-----------------------------------|------------------------------------|
| 1 Frame                   | 11 Cooling fan                    | 21 Refill hoses connection         |
| 2 Safety valve            | 12 Belt                           | 22 Working pressure gauge          |
| 3 Hose                    | 13 Purifier filter                | 23 ON pushbutton                   |
| 4 Refill valve            | 14 1st Stage                      | 24 STOP pushbutton                 |
| 5 Engine                  | 15 2nd Stage                      | 25 Condensate discharge pushbutton |
| 6 Compressor              | 16 3rd Stage                      | 26 Emergency pushbutton            |
| 7 Oil filler cap          | 17 4th Stage                      | 27 Hour counter                    |
| 8 Air filter              | 18 Condensate discharge valve     | 28 Selector switch ON/OFF          |
| 9 Oil discharge plug      | 19 Condensate collection can      | 29 Power indicator light           |
| 10 Anti-vibration devices | 20 Automatic condensate discharge |                                    |

Efficient line

# Smart

Electric



Smart 125EM

Smart 210EM<sup>1</sup>

Smart 235 ET

Smart 270 EM<sup>1</sup>

Smart 315 ET

Charging rate

125 l/min

210 l/min

235 l/min

270 l/min

315 l/min

Refill time<sup>2</sup>

16 min

10 min

8.30 min

7.20 min

6.20 min

Engine power

3 kW

Single-phase electric

4 kW

Single-phase electric

4 kW

Three-phase elec.

5,5 kW

Single-phase electric

5,5 kW

Three-phase elec.

<sup>1</sup>Data referred to the maximum pressure of 232 bar

<sup>2</sup>Filling time for 10l empty cylinder -0/200 bar (tolerance ±5%)

# The evolution of the species.

SMART breathing air compressors represent the evolution of the STANDARD, one of the best known and biggest selling models in the world. They are equipped with two connections for high pressure hoses, a single or three phase electric motor, indestructible pumping units and a compact frame with handles for easier transport. Available options: external refilling panels, electrical display with automatic condensate drainage, and autostop pressure gauge.

Working pressure from 232 to 420 bar

## Standard equipment

- |   |   |
|---|---|
| 1 | 2 filling connections to choose between<br>(1a) DIN 232, (1b) DIN 300 o (1c) INT/YOKE 232 bar |
| 2 | 2 filling hoses of 1.2 m length   |
| 3 | Pressure maintaining valve  |

- |   |                              |
|---|------------------------------|
| 4 | Maxifilter filtration system |
| 5 | Oil level auto cut off       |
| 6 | Carrying handles             |
| 7 | Frame color Blue RAL 5015    |

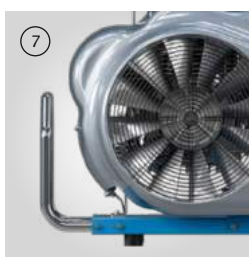
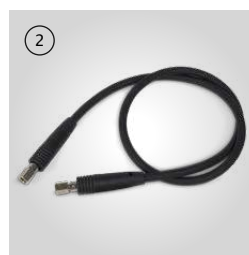
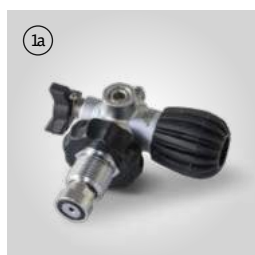

# Optional

1	C-Monitor	6	QR 232 bar with gauge
2	Remote control panel	7	QR 300 bar with gauge
3	Remote filling panel Single pressure 4 filling connections DIN 232	8	DIN/INT adapter
4	Remote filling panel Single pressure 4 filling connections DIN 300	9	Filling connection QR/INT
5	Remote filling panel Double pressure 2 DIN 232 + 2 DIN 300	10	Filling hose. Available: 1,5m – 2,0 m – 3,0 m – 4,0 m – 5,0 m – 8,0 m – 10,0 m
		11	Stainless steel frame





## Dimensions

Width 100 cm (39.9")

Depth 46 cm (18.1")

Height 70 cm (27.5")

## Dry weight

SMART 125EM

93 kg (205 lb)

SMART 210EM

100 kg (220 lb)

SMART 235 ET

95 kg (210 lb)

SMART 270 ET

105 kg (231 lb)

SMART 315 ET

105 kg (231 lb)

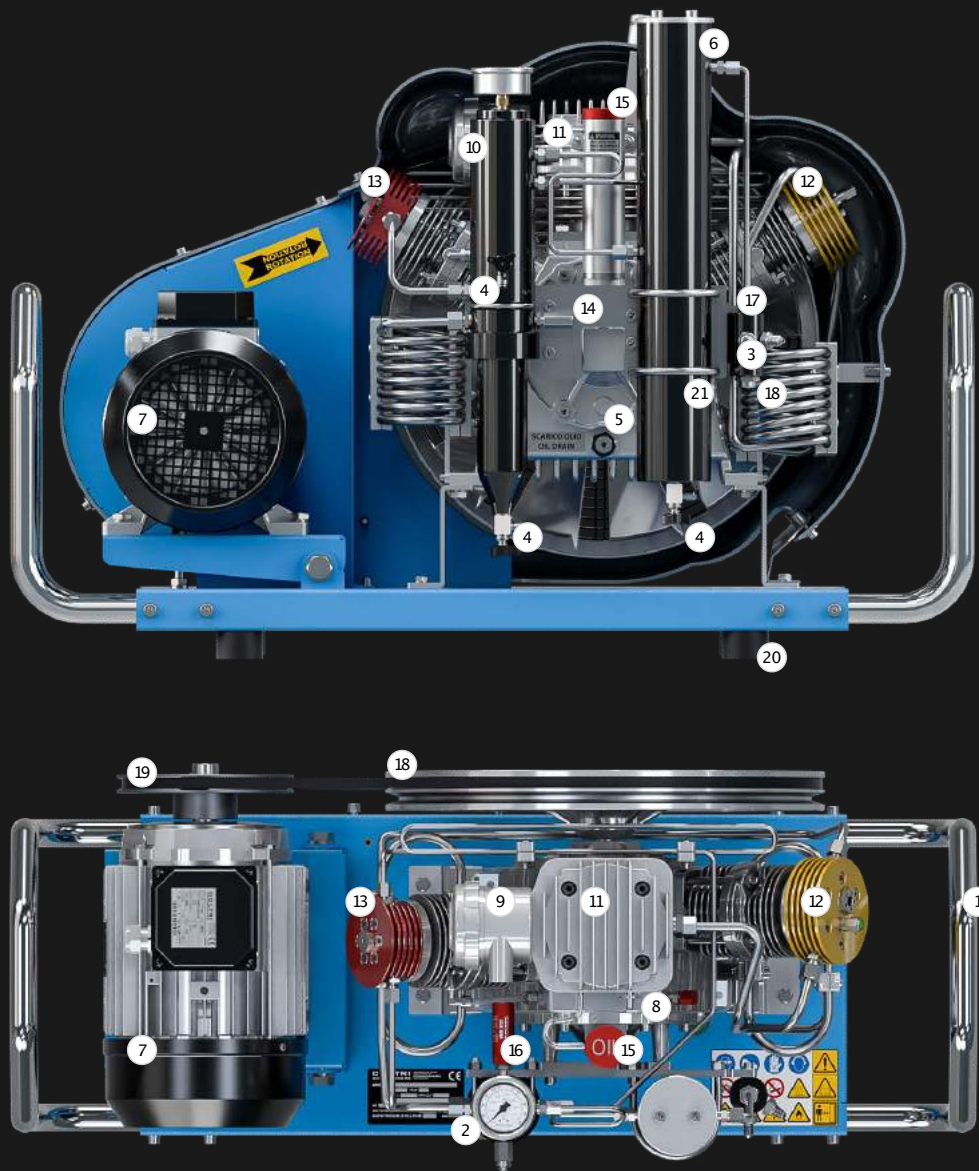

## Machine parts

- |                               |                         |                          |
|-------------------------------|-------------------------|--------------------------|
| 1 Frame                       | 8 Pumping unit          | 15 Oil filler plug       |
| 2 Pressure gauge              | 9 Air filter            | 16 Safety valve          |
| 3 Refill hoses connection     | 10 Condensate separator | 17 Maintenance valve     |
| 4 Condensate discharge valves | 11 1st stage            | 18 Cooling fan           |
| 5 Oil discharge valves        | 12 2nd stage            | 19 Belt                  |
| 6 Purification system         | 13 3rd stage            | 20 Anti-vibration device |
| 7 Electric motor              | 14 Monobloc             | 21 Oil level             |

Efficient line

# Mark III Silent

Electric



Mark III Silent  
210EM<sup>1</sup>

Mark III Silent  
235 ET

Mark III Silent  
270 EM<sup>1</sup>

Mark III Silent  
315 ET

Charging rate

210 l/min

235 l/min

270 l/min

315 l/min

Refill time<sup>2</sup>

10 min

8.30 min

7.20 min

6.20 min

Engine power

4 kW

Single-phase electric

4 kW

Three-phase electric

5,5 kW

Single-phase electric

5,5 kW

Three-phase electric

<sup>1</sup>Data referred to the maximum pressure of 232 bar

<sup>2</sup>Filling time 10l empty cylinder -0/200 bar (tolerance ±5%)

# Control is everything.

The Mark III Silent model is designed with control systems to effectively monitor all operations: interstage pressure, oil level, internal cabin temperature and rotation direction detector. With two connections for high pressure flexible hoses, it is equipped with electric motors and powerful pumping units, automatic condensate drain and electrical panel for managing the automatic compressor shutdown. Available options include the remote charging panel.

Working pressure from 232 to 420 bar

## Standard equipment

1	2 filling connections to choose between (1a) DIN 232, (1b) DIN 300 o (1c) INT/YOKE 232 bar
2	2 filling hoses of 1.2 m length
3	Pressure maintaining valve
4	Interstage control gauges
5	Maxifilter filtration system
6	Cabin temperature with automatic switch-off

7	Phase controller that prohibits reverse rotation
8	Pressure switch with automatic switch-off
9	Oil level auto cut off
10	Auto-drain Condensate System with condensate collection tank
11	Frame color Blue RAL 5015

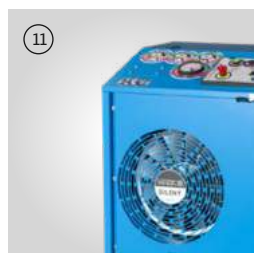
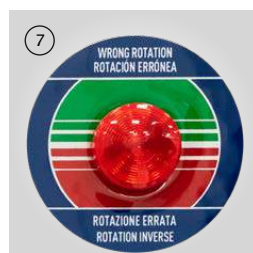
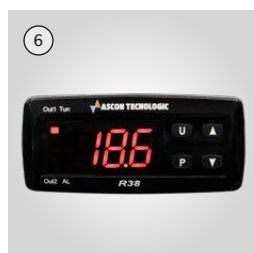
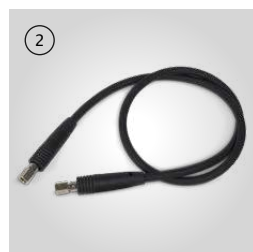

# Optional

1	C-Monitor	8	Filling connection IQR/INT
2	Remote filling panel Single pressure 4 filling connections DIN 232	9	Presec, filter control system
3	Remote filling panel Single pressure 4 filling connections DIN 300	10	SAM sensors CO + CO <sub>2</sub> + H <sub>2</sub> O Available in version with VOC.
4	Remote filling panel Double pressure 2 DIN 232 + 2 DIN 300	11	Tornado refrigerator – Dryer Available in 350 bar or 420 bar versions.
5	Filling connection with gauge QR 232 bar	12	Filling hose. Available: 1,5m – 2,0 m 3,0 m – 4,0 m – 5,0 m – 8,0 m – 10,0 m
6	Filling connection with gauge QR 300 bar	13	Stainless steel frame
7	DIN/INT adapter		

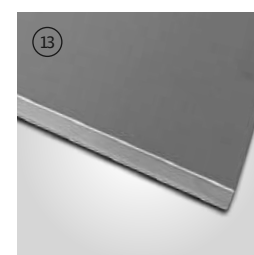



## Dimensions

Width 103 cm (40.5")

Depth 73 cm (28.7")

Height 91 cm (35.8")

## Dry weight

MARK III SILENT 210EM

162 kg (357 lb)

MARK III SILENT 235 ET

162 kg (357 lb)

MARK III SILENT 270 EM

168 kg (370 lb)

MARK III SILENT 315 ET

168 kg (370 lb)

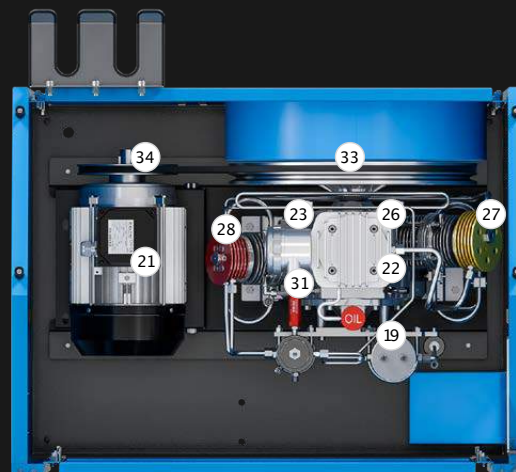
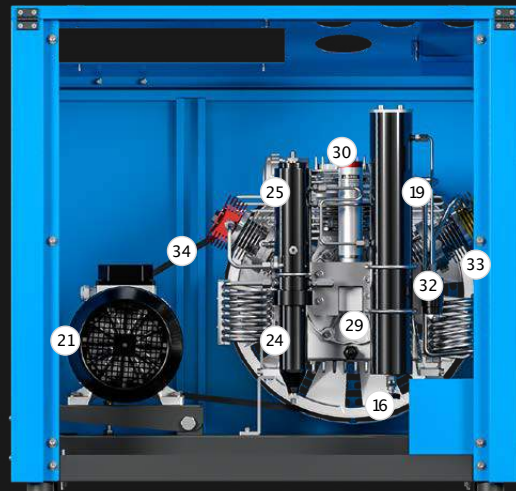
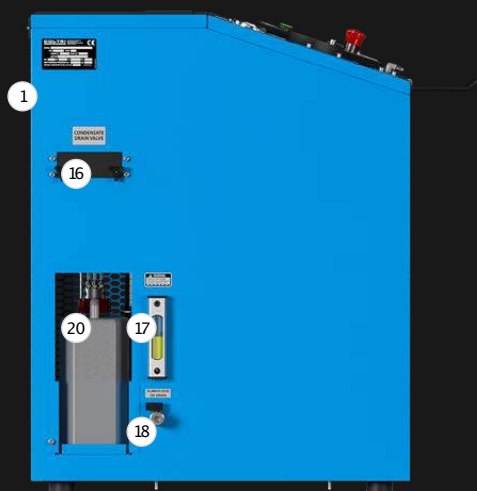

## Machine parts

- |  |                                |                            |
|--|--------------------------------|----------------------------|
| 1 Frame                                      | 12 3rd stage pressure gauge    | 24 LP condensate separator |
| 2 Control panel                              | 13 2nd stage pressure gauge    | 25 HP condensate separator |
| 3 ON pushbutton                              | 14 1st stage pressure gauge    | 26 1st stage               |
| 4 Stop pushbutton                            | 15 Refill hoses connection     | 27 2nd stage               |
| 5 Condensate discharge pushbutton            | 16 Condensate discharge valves | 28 3rd stage               |
| 6 Oil level warning light                    | 17 Oil level                   | 29 Monobloc                |
| 7 Direction of rotation indicator light      | 18 Oil discharge valves        | 30 Oil filler plug         |
| 8 Hour counter                               | 19 Purification system         | 31 Safety valve            |
| 9 Cabinet interior / cooling air temperature | 20 Condensate collection can   | 32 Maintenance valve       |
| 10 Emergency pushbutton                      | 21 Electric motor              | 33 Cooling fan             |
| 11 Automatic shutdown pressure switch        | 22 Pumping unit                | 34 Belt                    |
|  | 23 Air filter                  |                            |

Efficient line

# Ergo

Electric



Ergo 210EM<sup>1</sup>

Ergo 235 ET

Ergo 270 EM<sup>1</sup>

Ergo 315 ET

Charging rate

210 l/min

235 l/min

270 l/min

315 l/min

Refill time<sup>2</sup>

10 min

8.30 min

7.20 min

6.20 min

Engine power

4 kW

Single-phase electric

4 kW

Three-phase electric

5,5 kW

Single-phase electric

5,5 kW

Three-phase electric

<sup>1</sup>Data referred to the maximum pressure of 232 bar

<sup>2</sup>Filling time 10l empty cylinder -0/200 bar (tolerance ±5%)

# Maximum efficiency in motion.

Practical and lightweight, ERGO combines robustness and great operational efficiency. Equipped with two different pumping units, it can be powered by electric motors or Honda petrol/Kohlerdiesel engines. It is equipped with a monitoring panel complete with interstage pressure gauges, autostop with adjustable pressure switch, automatic condensate drain and rotation direction control. There are two connections for high pressure hoses (from 232 to 330 bar) and a Maxifilter filter system. The remote charging panel is available as an option.

Working pressure from 232 to 420 bar

## Standard equipment

- 1 2 filling connections to choose between (1a) DIN 232, (1b) DIN 300 o (1c) INT/YOKE 232 bar
- 2 2 filling hoses of 1.2 m length
- 3 Pressure maintaining valve
- 4 Interstage control gauges
- 5 Maxifilter filtration system
- 6 Cabin temperature with automatic switch-off

- 7 Phase controller that prohibits reverse rotation
- 8 Pressure switch with automatic switch-off
- 9 Oil level auto cut off
- 10 Auto-drain Condensate System with condensate collection tank
- 11 Frame color Blu RAL 5002

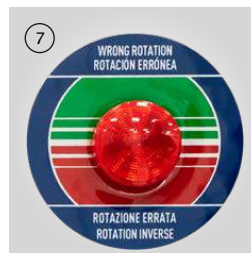
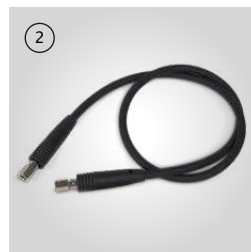

# Optional

1	C-Monitor	6	Filling connection with gauge QR 300 bar
2	Remote filling panel Single pressure 4 filling connections DIN 232	7	DIN/INT adapter
3	Remote filling panel Single pressure 4 filling connections DIN 300	8	Filling connection QR/INT
4	Remote filling panel Double pressure 2 DIN 232 + 2 DIN 300	9	Filling hose. Available: 1,5m – 2,0 m 3,0 m – 4,0 m – 5,0 m – 8,0 m – 10,0 m
5	Filling connection with gauge QR 232 bar	10	Wheel kit
		11	Stainless steel frame

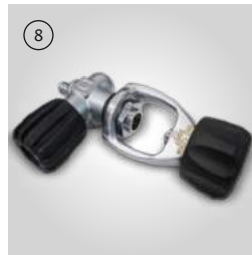



## Dimensions

Width 112cm (44.1")  
 Depth 63 cm (24.8")  
 Height 77 cm (30.3")

## Dry weight

ERGO 210 EM  
 159 kg (350 lb)  
 ERGO 235 ET  
 159 kg (350 lb)  
 ERGO 270 EM  
 147 kg (324 lb)  
 ERGO 315 ET  
 152 kg (335 lb)

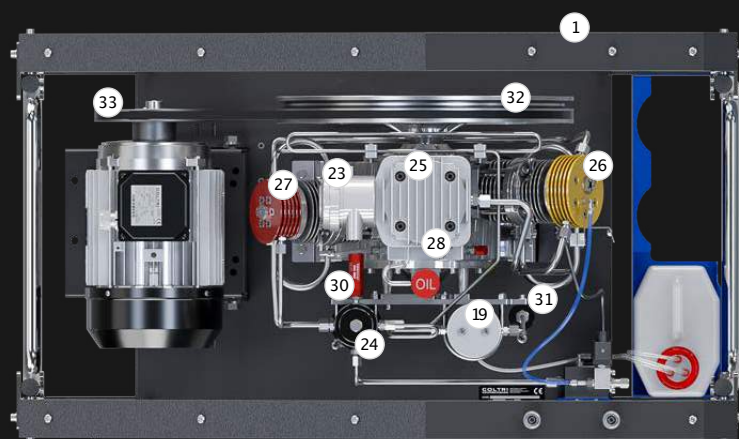
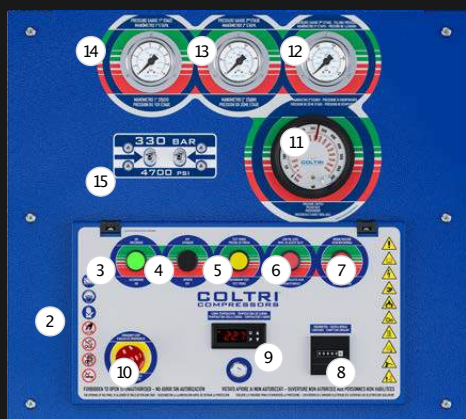
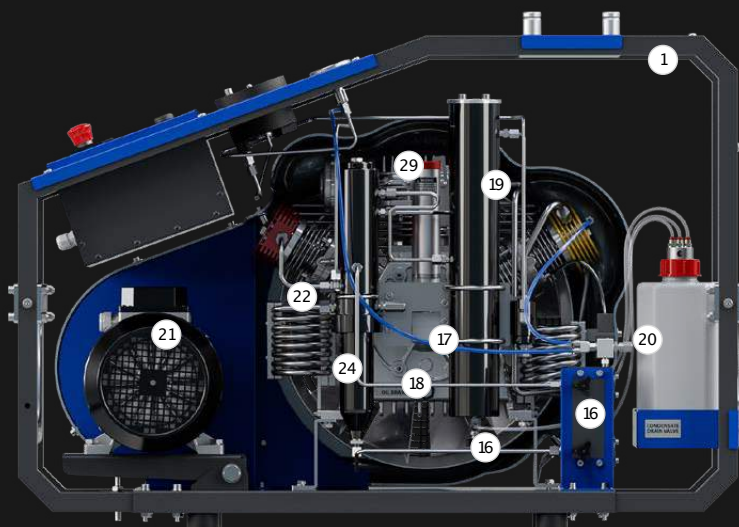

## Machine parts

- |  |                                |                               |
|--|--------------------------------|-------------------------------|
| 1 Frame                                    | 12 3rd stage pressure gauge    | 24 Final condensate separator |
| 2 Control panel                            | 13 2nd stage pressure gauge    | 25 1st stage                  |
| 3 ON pushbutton                            | 14 1st stage pressure gauge    | 26 2nd stage                  |
| 4 Stop pushbutton                          | 15 Refill hoses connection     | 27 3rd stage                  |
| 5 Condensate discharge pushbutton          | 16 Condensate discharge valves | 28 Monoblock                  |
| 6 Oil level warning light                  | 17 Oil level                   | 29 Oil filler plug            |
| 7 Direction of rotation indicator light    | 18 Oil discharge valves        | 30 Safety valve               |
| 8 Hour counter                             | 19 Purification system         | 31 Maintenance valve          |
| 9 Cabinet interior/cooling air temperature | 20 Condensate collection tank  | 32 Cooling fan                |
| 10 Emergency pushbutton                    | 21 Electric motor              | 33 Belt                       |
| 11 Automatic shutdown pressure switch      | 22 Pumping unit                |                               |
|  | 23 Air filter                  |                               |

Efficient line

# Ergo

Petrol – Diesel



Ergo 285 Petrol

Ergo 285 Diesel

Charging rate

285 l/min

270 l/min

Refill time<sup>1</sup>

7 min

7.20 min

Engine power

6,6 kW

Petrol HONDA GX 270

7,5 kW

Diesel Kohler KD15-440

<sup>1</sup> Filling time 10l empty cylinder -0/200 bar (tolerance ±5%)

Working pressure from 232 to 420 bar

## Standard equipment

- |   |   |
|---|---|
| 1 | 2 filling connections to choose between<br>(1a) DIN 232, (1b) DIN 300 o (1c) INT/YOKE 232 bar |
| 2 | 2 filling hoses of 1.2 m length   |
| 3 | Pressure maintaining valve  |

- |   |                                |
|---|--------------------------------|
| 4 | Maxifilter purification system |
| 5 | Oil level auto cut off         |
| 6 | Frame color Blu RAL 5002       |

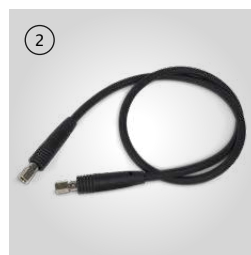

# Optional

- 1 C-Monitor
- 2 Remote filling panel  
Single pressure 4 filling connections DIN 232
- 3 Remote filling panel  
Single pressure 4 filling connections DIN 300
- 4 Remote filling panel  
Double pressure 2 DIN 232 + 2 DIN 300
- 5 QR 232 bar with gauge
- 6 QR 300 bar with gauge
- 7 DIN/INT adapter
- 8 Filling connection QR/INT

- 9 Filling hose. Available: 1,5m – 2,0 m  
– 3,0 m – 4,0 m – 5,0 m – 8,0 m – 10,0 m
- 10 Auto-drainCondensate System with condensate  
collection tank  
Only with electric start motors and battery
- 11 Electric starter
- 12 Digital hour meter  
Only for Honda engine
- 13 Wheel kit
- 14 Stainless steel frame

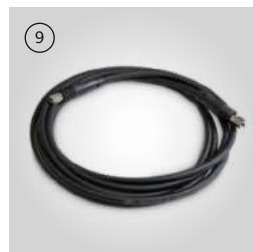
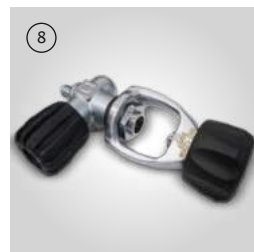



## Dimensions

Width 112cm (44.1")

Depth 63 cm (24.8")

Height 77 cm (30.3")

## Dry weight

ERGO 285 Petrol

121kg (267 lb)

ERGO 270 Diesel

164 kg (362 lb)

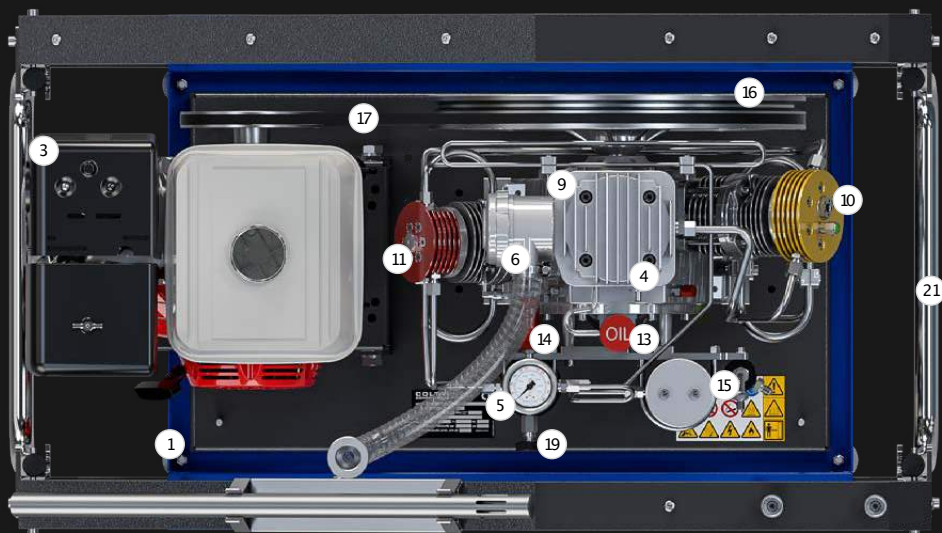
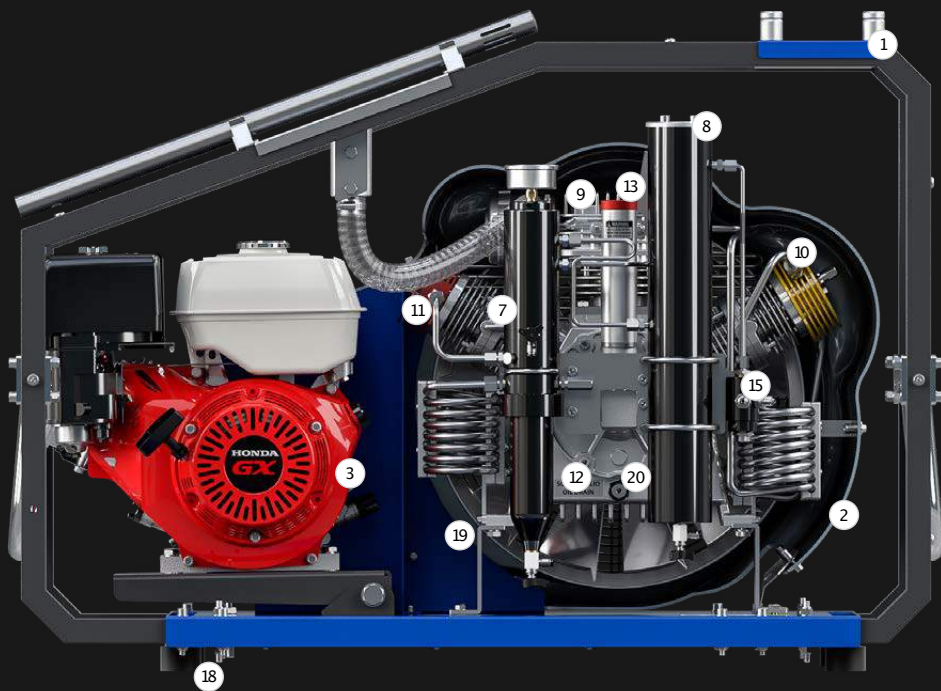

## Machine parts

- |                               |                               |                      |
|-------------------------------|-------------------------------|----------------------|
| 1 Frame                       | 8 Compressor                  | 15 Oil filler plug   |
| 2 Pressure gauge              | 9 Air filter                  | 16 Safety valve      |
| 3 Refill hoses connection     | 10 Final condensate separator | 17 Maintenance valve |
| 4 Condensate discharge valves | 11 1st stage                  | 18 Cooling fan       |
| 5 Oil discharge valves        | 12 2nd stage                  | 19 Belt              |
| 6 Purifier filter             | 13 3rd stage                  | 20 Antivibrations    |
| 7 Combustion engine           | 14 Monoblock                  | 21 Handles           |

Efficient line

# Super Silent

Electric



Super Silent 235 ET

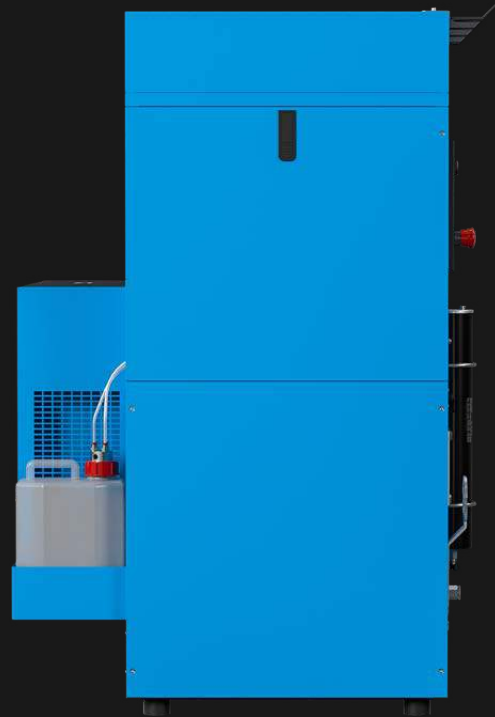

Super Silent 315 ET



Super Silent 330 ET

Charging rate

235 l/min

315 l/min

330 l/min

Refill time<sup>1</sup>

8.30 min

6.20 min

6.00 min

Engine power

4 kW

5,5 kW

7,5 kW

Three-phase electric

Three-phase electric

Three-phase electric

<sup>1</sup> Filling time 10l empty cylinder -0/200 bar (tolerance ±5%)

# Super, without the noise.

The SUPER SILENT model stands out for its outstanding noise reduction. Easy to use, it features a high monitoring capability through control systems that track compressor operations. Standard equipment includes: two connections for high pressure hoses, interstage pressure gauge, oil level and internal cabin temperature control, rotation detector, electric motor, automatic condensate drain and autostop. Choose the best pumping group for your needs.

Working pressure from 232 to 420 bar

## Standard equipment

- 1 2 filling connections to choose between (1a) DIN 232, (1b) DIN 300 o (1c) INT/YOKE 232 bar
- 2 2 filling hoses of 1.2 m length
- 3 Pressure maintaining valve
- 4 Interstage control gauges
- 5 Maxifilter filtration system
- 6 Cabin temperature with automatic switch-off

- 7 Phase controller that prohibits reverse rotation
- 8 Pressure switch with automatic switch-off
- 9 Oil level auto cut off
- 10 Auto-drain Condensate System with condensate collection tank
- 11 Frame color Blue RAL 5015

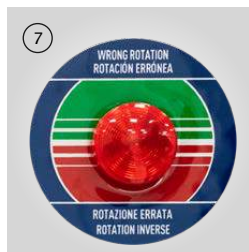
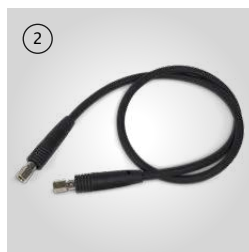
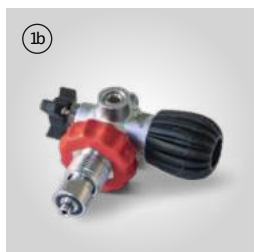
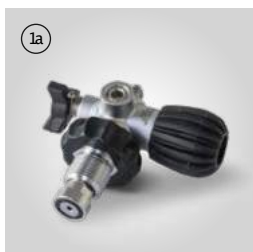

# Optional

1	C-Monitor	6	Filling connection with gauge QR 300 bar
2	Remote filling panel Single pressure 4 filling connections DIN 232	7	DIN/INT adapter
3	Remote filling panel Single pressure 4 filling connections DIN 300	8	Filling connection QR/INT
4	Remote filling panel Double pressure 2 DIN 232 + 2 DIN 300	9	SAM sensors CO + CO2 + H2O Available in version with VOC.
5	Filling connection with gauge QR 232 bar	10	Filling hose. Available: 1,5m – 2,0 m 3,0 m – 4,0 m – 5,0 m – 8,0 m – 10,0 m
		11	Stainless steel frame

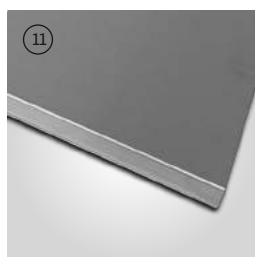
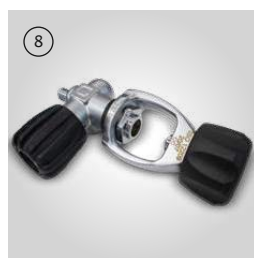



## Dimensions

Width 90 cm (35.4")

Depth 91 cm (35.8")

Height 132 cm (53")

## Dry weight

SUPER SILENT 235 ET

192 kg (423 lb)

SUPER SILENT 315 ET

202 kg (445 lb)

SUPER SILENT 330 ET

202 kg (445 lb)

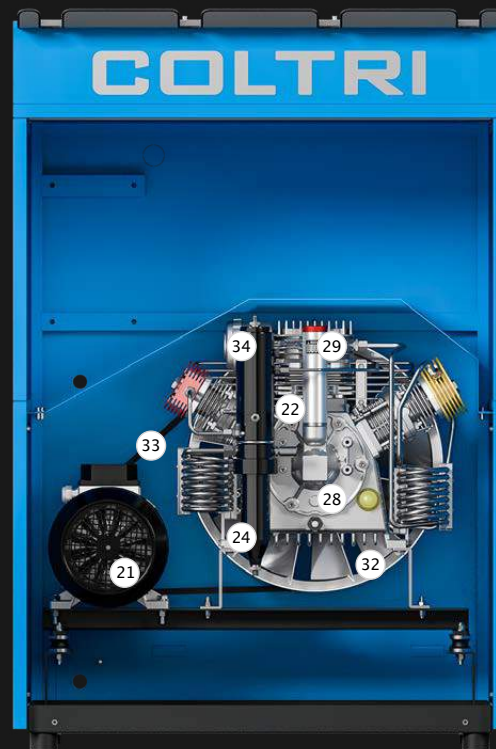
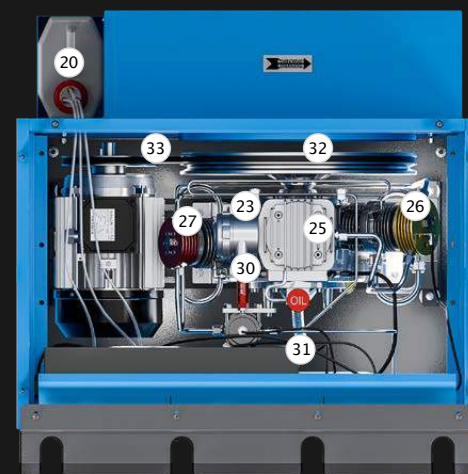
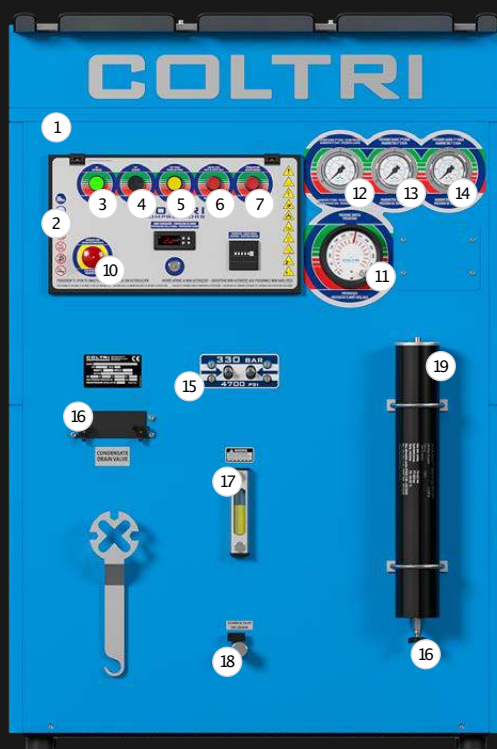

## Machine parts

- |  |                                |                            |
|--|--------------------------------|----------------------------|
| 1 Frame                                      | 12 3rd stage pressure gauge    | 24 LP condensate separator |
| 2 Control panel                              | 13 2nd stage pressure gauge    | 25 1st stage               |
| 3 ON pushbutton                              | 14 1st stage pressure gauge    | 26 2nd stage               |
| 4 Stop pushbutton                            | 15 Refill hoses connection     | 27 3rd stage               |
| 5 Condensate discharge pushbutton            | 16 Condensate discharge valves | 28 Monobloc                |
| 6 Oil level warning light                    | 17 Oil level                   | 29 Oil filler plug         |
| 7 Direction of rotation indicator light      | 18 Oil discharge valves        | 30 Safety valve            |
| 8 Hour counter                               | 19 Purification system         | 31 Maintenance valve       |
| 9 Cabinet interior / cooling air temperature | 20 Condensate collection can   | 32 Cooling fan             |
| 10 Emergency pushbutton                      | 21 Electric motor              | 33 Belt                    |
| 11 Automatic shutdown pressure switch        | 22 Pumping unit                | 34 HP condensate separator |
|  | 23 Air filter                  |                            |

Prime line

# Mark III Silent TPS

Electric



Mark III  
Silent TPS  
210 EM

Mark III  
Silent TPS  
235 ET

Mark III  
Silent TPS  
270 EM <sup>1</sup>

Mark III  
Silent TPS  
315 ET

Mark III  
Silent TPS  
345 ET

Mark III  
Silent TPS  
380 ET

Charging rate

210 l/min

235 l/min

270 l/min

315 l/min

345 l/min

380 l/min

Refill time<sup>2</sup>

10 min

8.30 min

7.20 min

6.20 min

5.40 min

5.15 min

Engine power

4 kW

Single-phase  
electric

4 kW

Three-phase  
electric

5,5 kW

Single-phase electric

5,5 kW

Three-phase  
electric

7,5 kW

Three-phase  
electric

7,5 kW

Three-phase  
electric

<sup>1</sup> Data referred to the maximum pressure of 232 bar

<sup>2</sup> Filling time 10l empty cylinder -0/200 bar (tolerance ±5%)

# No compromise.

The Mark III Silent TPS range is ideal for intensive use in hot, poorly ventilated environments or in tropical countries. Designed with an improved cooling system and a filtering system with two Hyperfilters, these compressors are powered by an electric motor and equipped with four different pumping units, all in TPS (Tropical Plus Superdry) version. They are available with function monitoring systems and electrical panel for automatic compressor shutdown.

Working pressure from 232 to 420 bar

## Standard equipment

1	2 filling connections to choose between (1a) DIN 232, (1b) DIN 300 o (1c) INT/YOKE 232 bar	8	Phase controller that prohibits reverse rotation
2	2 filling hoses of 1.2 m length	9	Electronic pressure switch with automatic switch-off
3	Pressure maintaining valve	10	Oil level auto cut off
4	Interstage control gauges	11	Oil pump with filter and pressure gauge
5	Double filtering system Hyperfilter certified PED	12	Auto-drain Condensate System with condensate collection tank
6	Cabin temperature with automatic switch-off	13	Frame color Blu RAL 5002
7	Automatic condensate drain		

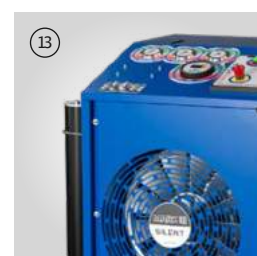
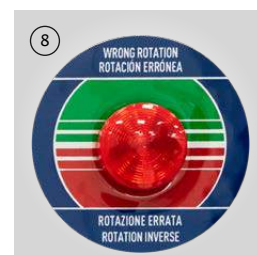
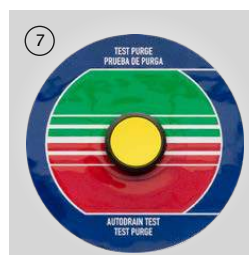
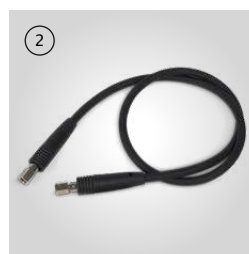
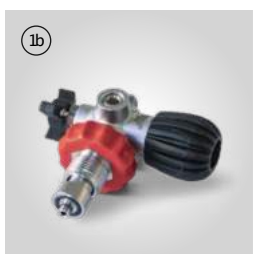
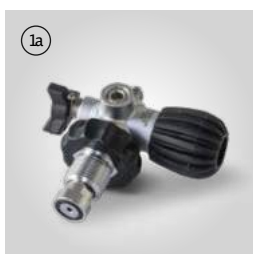

# Optional

1	C-Monitor	7	Filling connection with gauge QR 232 bar
2	Remote filling panel Single pressure 4 filling connections DIN 232	8	Filling connection with gauge QR 300 bar
3	Remote filling panel Single pressure 4 filling connections DIN 300	9	DIN/INT adapter
4	Remote filling panel Double pressure 2 DIN 232 + 2 DIN 300	10	Filling connection QR/INT
5	Remote filling panel con rubinetti a leva Pressione singola 4 INT + 4 DIN 232 + 4 DIN 300	11	Presec, filter control system
6	Remote filling panel con rubinetti a leva Pressione doppia 2 INT + 1 DIN 232 + 1 DIN 300	12	SAM sensors CO + CO2 + H2O Available in version with VOC.
		13	Filling hose. Available: 1,5m - 2,0 m 3,0 m - 4,0 m - 5,0 m - 8,0 m - 10,0 m
		14	Stainless steel frame





## Dimensions

Width 112cm (44.1")

Depth 73 cm (28.7")

Height 91 cm (38.8")

## Dry weight

MARK III SILENT TPS 210EM

181kg (399 lb)

MARK III SILENT TPS 235 ET

181kg (399 lb)

MARK III SILENT TPS 270 EM

191kg (421 lb)

MARK III SILENT TPS 315 ET

191kg (421 lb)

MARK III SILENT TPS 345 ET

191kg (421 lb)

MARK III SILENT TPS 380 ET

191kg (421 lb)

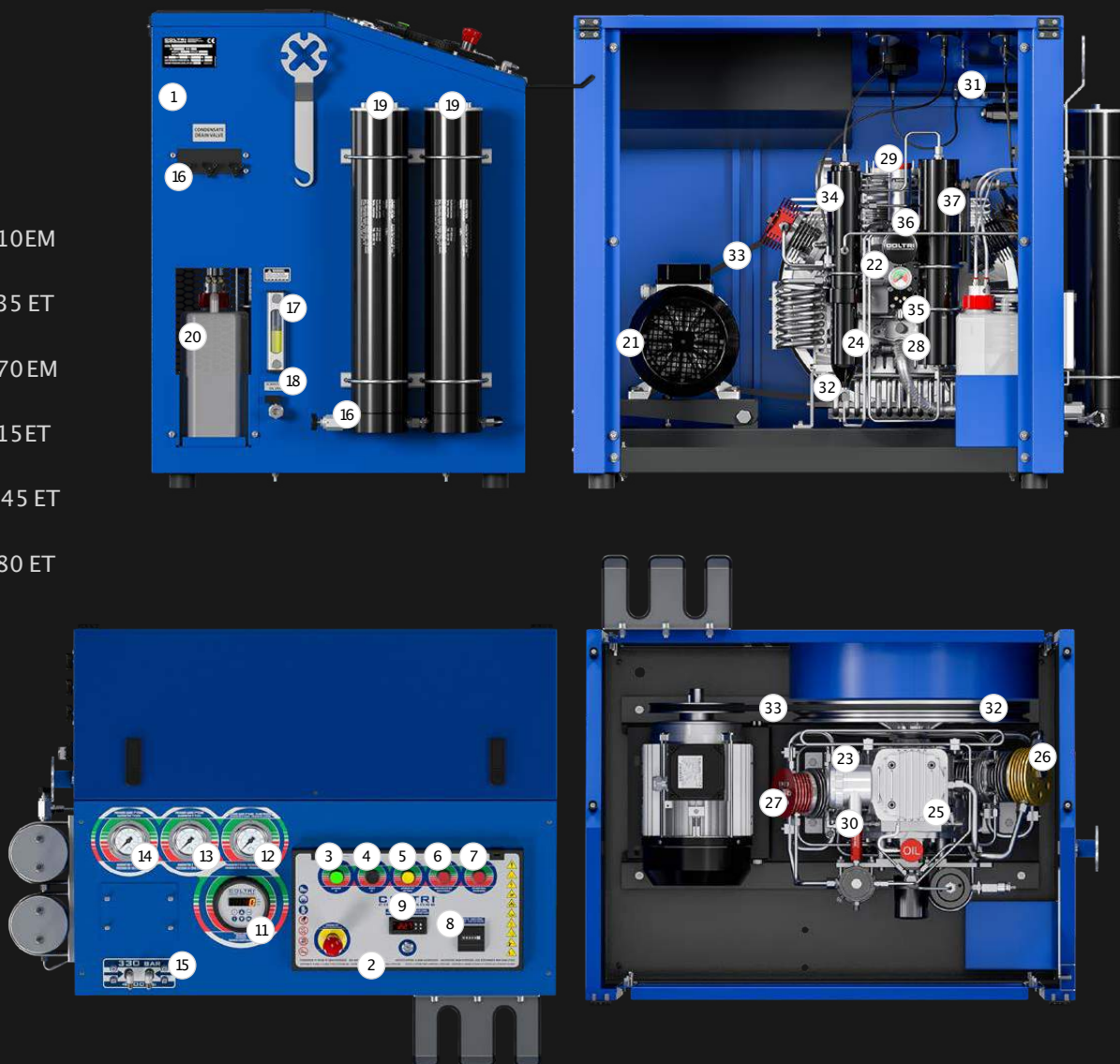

## Machine parts

- |  |                                |  |
|--|--------------------------------|--|
| 1 Frame                                      | 13 2nd stage pressure gauge    | 26 2nd stage                               |
| 2 Control panel                              | 14 1st stage pressure gauge    | 27 3rd stage                               |
| 3 ON pushbutton                              | 15 Refill hoses connection     | 28 Monobloc                                |
| 4 Stop pushbutton                            | 16 Condensate discharge valves | 29 Oil filler plug                         |
| 5 Condensate discharge pushbutton            | 17 Oil level                   | 30 Safety valve                            |
| 6 Oil level warning light                    | 18 Oil discharge valves        | 31 Maintenance valve                       |
| 7 Direction of rotation indicator light      | 19 Purification system         | 32 Cooling fan                             |
| 8 Hour counter                               | 20 Condensate collection can   | 33 Belt                                    |
| 9 Cabinet interior / cooling air temperature | 21 Electric motor              | 34 HP condensate separator                 |
| 10 Emergency pushbutton                      | 22 Pumping unit                | 35 Oil pump                                |
| 11 Automatic shutdown pressure switch        | 23 Air filter                  | 36 Oil filter                              |
| 12 3rd stage pressure gauge                  | 24 LP condensate separator     | 37 HP High Efficiency condensate separator |
|  | 25 1st stage                   |  |

Prime line

# Ergo TPS

Electric



Ergo TPS  
235 ET

Ergo TPS  
270 EM <sup>1</sup>

Ergo TPS  
315 ET

Ergo TPS  
345 ET

Ergo TPS  
380 ET

Charging rate

235 l/min

270 l/min

315 l/min

345 l/min

380 l/min

Refill time<sup>2</sup>

8.30 min

7.20 min

6.20 min

5.40 min

5.15 min

Engine power

4 kW

5,5 kW

5,5 kW

7,5 kW

7,5 kW

Three-phase electric

Single-phase electric

Three-phase electric

Three-phase electric

Three-phase electric

<sup>1</sup>Data referred to the maximum pressure of 232 bar

<sup>2</sup>Filling time 10l empty cylinder -0/200 bar (tolerance ±5%)

# Less is more.

ERGO TPS is the best solution for those who want a compact breathing air compressor without compromising on high performance. Equipped with four different TPS (Tropical Plus Superdry) pumping units, ERGO TPS is powered by electric motors or engines (Honda for the petrol version, Kohler for the diesel compressors). It has a panel with a monitoring system complete with pressure gauges, autostop with adjustable electronic pressure switch, automatic condensate drain and rotation direction control. It also has two connections for high pressure hoses and an improved filtering system with two Hyperfilters. The remote charging panel is available as an option.

Working pressure from 232 to 420 bar

## Standard equipment

1	2 filling connections to choose between (1a) DIN 232, (1b) DIN 300 o (1c) INT/YOKE 232 bar	8	Phase controller that prohibits reverse rotation
2	2 filling hoses of 1.2 m length	9	Electronic pressure switch with automatic switch-off
3	Pressure maintaining valve	10	Oil level auto cut off
4	Interstage control gauges	11	Oil pump with filter and pressure gauge
5	Double filtering system Hyperfilter certified PED	12	Auto-drain Condensate System with condensate collection tank
6	Cabin temperature with automatic switch-off	13	Carrying handles
7	Automatic condensate drain	14	Frame color Blue RAL 5002

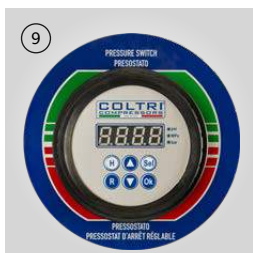
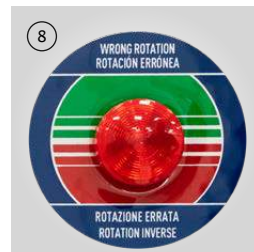
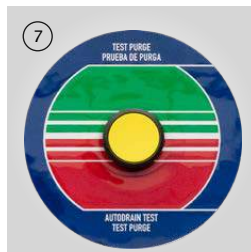
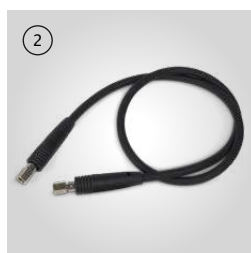
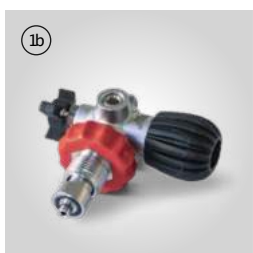
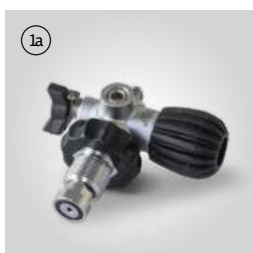

## Optional

1	C-Monitor	7	Filling connection with gauge QR 232 bar
2	Remote filling panel Single pressure 4 filling connections DIN 232	8	Filling connection with gauge QR 300 bar
3	Remote filling panel Single pressure 4 filling connections DIN 300	9	DIN/INT adapter
4	Remote filling panel Double pressure 2 DIN 232 + 2 DIN 300	10	Filling connection QR/INT
5	Remote filling panel con rubinetti a leva Pressione singola 4 INT + 4 DIN 232 + 4 DIN 300	11	Presec, filter control system
6	Remote filling panel con rubinetti a leva Pressione doppia 2 INT + 1 DIN 232 + 1 DIN 300	12	Filling hose. Available: 1,5m - 2,0 m 3,0 m - 4,0 m - 5,0 m - 8,0 m - 10,0 m
		13	Wheel kit
		14	Stainless steel frame





## Dimensions

Width 112cm (44.1")

Depth 63 cm (24.8")

Height 77 cm (30.3")

## Dry weight

ERGO TPS 235 ET

174 kg (384 lb)

ERGO TPS 270 EM /ERGO TPS 315 ET

184 kg (406 lb)

ERGO TPS 345 ET /ERGO TPS 380 ET

184 kg (406 lb)

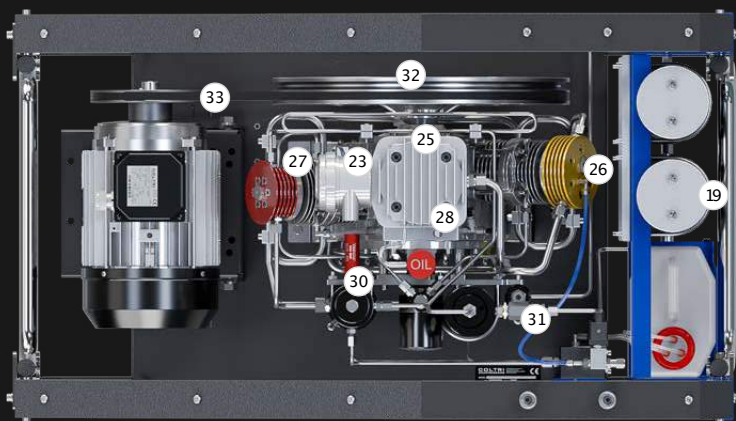
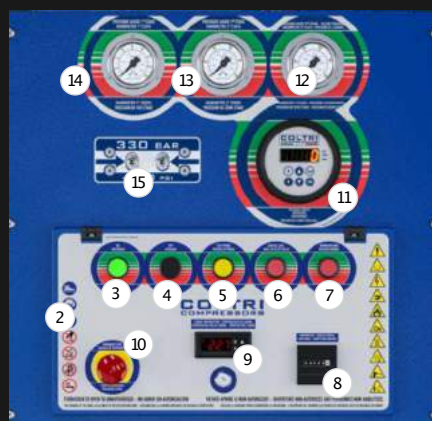
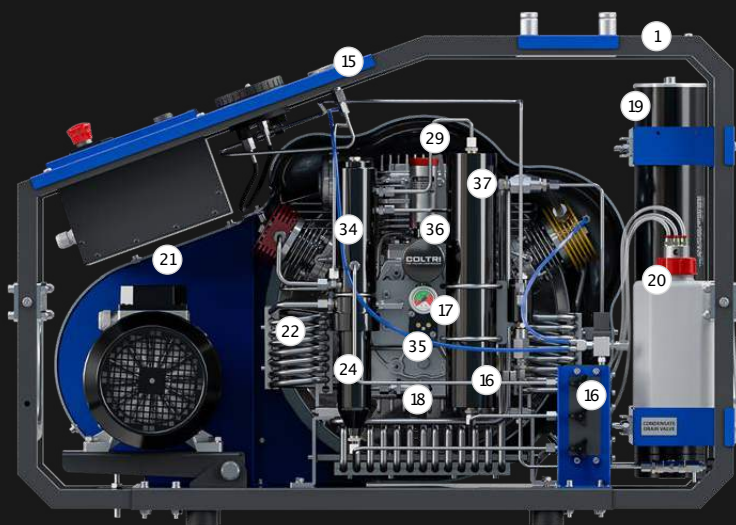

## Machine parts

- |   |                                |  |
|---|--------------------------------|--|
| 1 Frame                                     | 13 2nd stage pressure gauge    | 26 2nd stage                               |
| 2 Control panel                             | 14 1st stage pressure gauge    | 27 3rd stage                               |
| 3 ON pushbutton                             | 15 Refill hoses connection     | 28 Monobloc                                |
| 4 Stop pushbutton                           | 16 Condensate discharge valves | 29 Oil filler plug                         |
| 5 Condensate discharge pushbutton           | 17 Oil level                   | 30 Safety valve                            |
| 6 Oil level warning light                   | 18 Oil discharge valves        | 31 Maintenance valve                       |
| 7 Direction of rotation indicator light     | 19 Purification system         | 32 Cooling fan                             |
| 8 Hour counter                              | 20 Condensate collection can   | 33 Belt                                    |
| 9 Cabinet interior /cooling air temperature | 21 Electric motor              | 34 HP condensate separator                 |
| 10 Emergency pushbutton                     | 22 Pumping unit                | 35 Oil pump                                |
| 11 Automatic shutdown pressure switch       | 23 Air filter                  | 36 Oil filter                              |
| 12 3rd stage pressure gauge                 | 24 LP condensate separator     | 37 HP High Efficiency condensate separator |
|   | 25 1st stage                   |  |

Prime line

# Super Silent TPS

Electric



Super Silent TPS  
235 ET

Super Silent TPS  
270 EM <sup>1</sup>

Super Silent TPS  
315 ET

Super Silent TPS  
345 ET

Super Silent TPS  
380 ET

Charging rate

235 l/min

270 l/min

315 l/min

345 l/min

380 l/min

Refill time <sup>2</sup>

8.30 min

7.20 min

6.20 min

5.40 min

5.15 min

Engine power

4 kW

Elettrico trifase

5,5 kW

Single-phase electric

5,5 kW

Three-phase electric

7,5 kW

Three-phase electric

7,5 kW

Three-phase electric

<sup>1</sup>Data referred to the maximum pressure of 232 bar

<sup>2</sup> Filling time 10l empty cylinder -0/200 bar (tolerance ±5%)

# Listen to its absolute silence.

The SUPER SILENT TPS model is specifically designed to minimise noise. It features an enhanced cooling and sound insulation system and an efficient filtering system with two Hyperfilters. Powered by an electric motor, it has four different pumping units, all in the TPS (Tropical Plus Superdry) version, and an intuitive control panel. For longer filter life, we recommend the Tornado high pressure dryer.

Working pressure from 232 to 420 bar

## Standard equipment

1	2 filling connections to choose between (1a) DIN 232, (1b) DIN 300 o (1c) INT/YOKE 232 bar	8	Phase controller that prohibits reverse rotation
2	2 filling hoses of 1.2 m length	9	Electronic pressure switch with automatic switch-off
3	Pressure maintaining valve	10	Oil level auto cut off
4	Interstage control gauges	11	Oil pump with filter and pressure gauge
5	Double filtering system Hyperfilter certified PED	12	Auto-drain Condensate System with condensate collection tank
6	Cabin temperature with automatic switch-off	13	Frame color Blu RAL 5002
7	Automatic condensate drain		

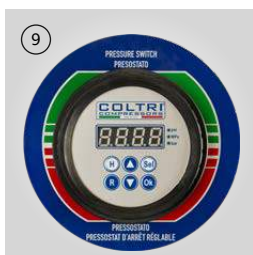
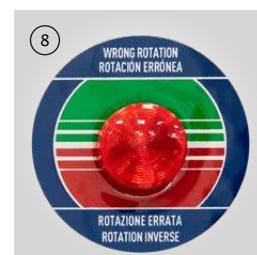
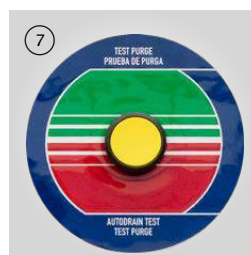
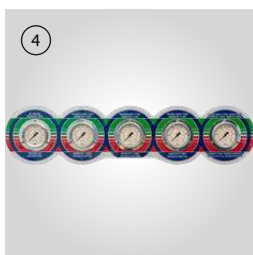
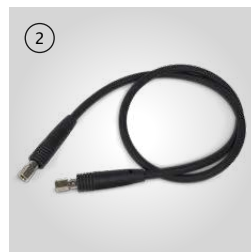
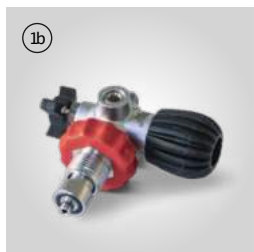
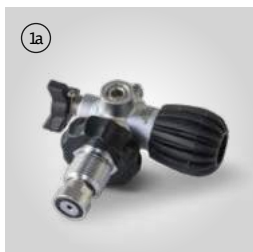

# Optional

- 1 Remote filling panel  
Single pressure 4 filling connections DIN 232

---

- 2 Remote filling panel  
Single pressure 4 filling connections DIN 300

---

- 3 Remote filling panel  
Double pressure 2 DIN 232 + 2 DIN 300

---

- 4 Remote filling panel con rubinetti a leva Pressione singola 4 INT + 4 DIN 232 + 4 DIN 300

---

- 5 Remote filling panel con rubinetti a leva Pressione doppia 2 INT + 1 DIN 232 + 1 DIN 300

---

- 6 Filling connection with gauge QR 232 bar

---

- 7 Filling connection with gauge QR 300 bar

---

- 8 DIN/INT adapter

---

- 9 Filling connection QR/INT

---

- 10 Presec, filter control system

---

- 11 SAM sensors CO + CO2 + H2O  
Available in version with VOC.

---

- 12 Tornado refrigerator - Dryer  
Available in 350 bar or 420 bar versions.

---

- 13 Filling hose. Available: 1,5m - 2,0 m  
3,0 m - 4,0 m - 5,0 m - 8,0 m - 10,0 m

---

- 14 Stainless steel frame

---





## Dimensions

Width 90 cm (35.4")

Depth 93 cm (36.6")

Height 132 cm (52")

## Dry weight

SUPER SILENT TPS 235 ET

212 kg (467 lb)

SUPER SILENT TPS 270 EM

SUPER SILENT TPS 315 ET

SUPER SILENT TPS 345 ET

SUPER SILENT TPS 380 ET

222 kg (489 lb)

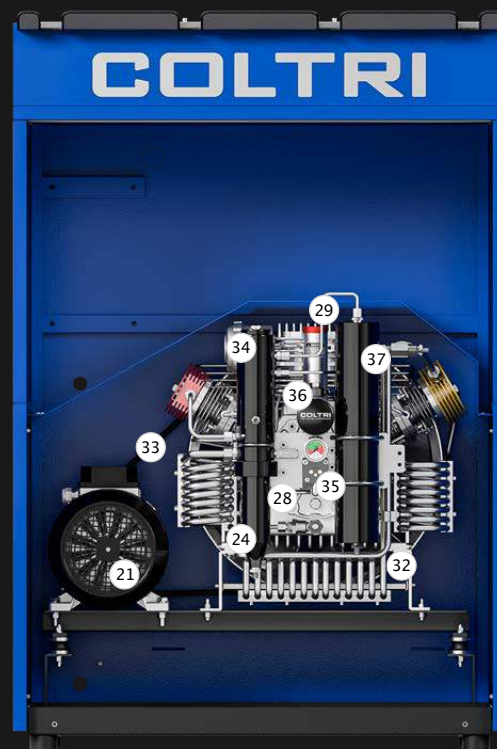
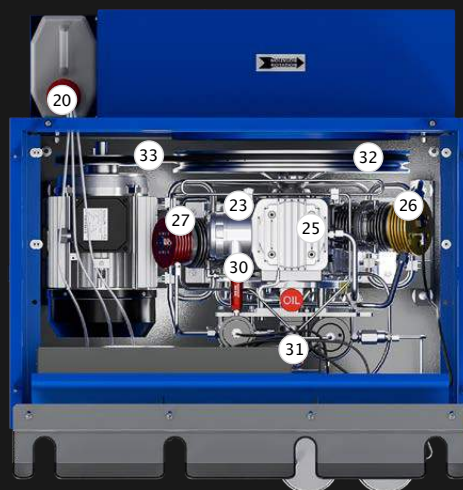

## Machine parts

- |  |                                |                               |
|--|--------------------------------|-------------------------------|
| 1 Frame                                      | 13 2nd stage pressure gauge    | 25 Final condensate separator |
| 2 Control panel                              | 14 1st stage pressure gauge    | 26 1st stage                  |
| 3 ON pushbutton                              | 15 Refill hoses connection     | 27 2nd stage                  |
| 4 Stop pushbutton                            | 16 Condensate discharge valves | 28 3rd stage                  |
| 5 Condensate discharge pushbutton            | 17 Oil level                   | 29 Monobloc                   |
| 6 Oil level warning light                    | 18 Oil discharge valves        | 30 Oil filler plug            |
| 7 Direction of rotation indicator light      | 19 Purification system         | 31 Safety valve               |
| 8 Hour counter                               | 20 Hole for suction extension  | 32 Maintenance valve          |
| 9 Cabinet interior / cooling air temperature | 21 Condensate collection tank  | 33 Cooling fan                |
| 10 Emergency pushbutton                      | 22 Electric motor              | 34 Belt                       |
| 11 Automatic shutdown pressure switch        | 23 Pumping unit                | 35 Antivibration              |
| 12 3rd stage pressure gauge                  | 24 Air filter                  | 36 Oil pump                   |

Heavy Duty line

# Open

Electric



Open 450 EM

Open 450 ET

Open 550 ET

Open 650 ET

Open 750 ET

Charging rate

450 l/min

450 l/min

550 l/min

650 l/min

750 l/min

Refill time<sup>1</sup>

4.30 min

4.30 min

4 min

3 min

2.40 min

Engine power

7,5 kW

Single-phase electric

7,5 kW

Three-phase electric

9 kW

Three-phase electric

11 kW

Three-phase electric

15 kW

Three-phase electric

<sup>1</sup> Filling time 10l empty cylinder -0/200 bar (tolerance ±5%)

# Top performance, even when charging.

The OPEN model meets professional needs that require large charging capacities in hot, poorly ventilated environments or tropical countries. It has 4 front filling connections for high pressure hoses, an intuitive control panel and an electric motor. The pumping group, chosen from the 4 most powerful, is exposed in the rear housing to ensure a better cooling cycle. For longer filter life, we recommend the Tornado high pressure dryer. Available option: Presec system for filter saturation control or the SAM system for multigas analysis and remote charging panel.

Working pressure from 232 to 420 bar

## Standard equipment

- 1 2 filling connections to choose between (1a) DIN 232, (1b) DIN 300 o (1c) INT/YOKE 232 bar
- 2 2 filling hoses of 1.2 m length
- 3 Pressure maintaining valve
- 4 Interstage control gauges
- 5 Double filtering system Hyperfilter certified PED
- 6 Cabin temperature with automatic switch-off
- 7 Automatic condensate drain

- 8 Phase controller that prohibits reverse rotation
- 9 Electronic pressure switch with automatic switch-off
- 10 Oil level auto cut off
- 11 Oil pump
- 12 Auto-drain Condensate System with condensate collection tank
- 13 Frame color Blu RAL 5015

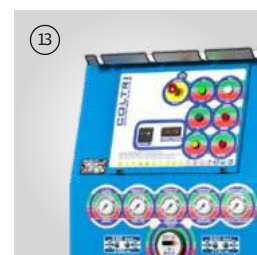
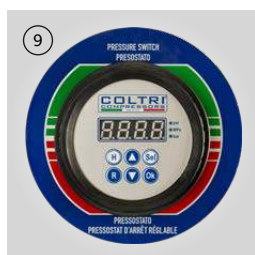
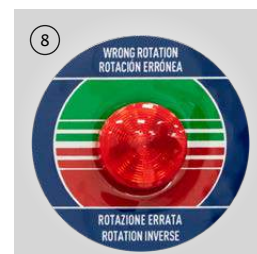
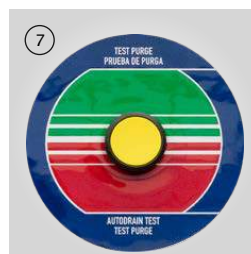
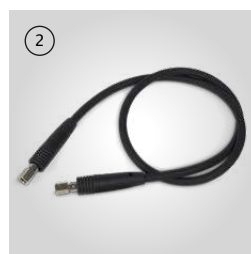
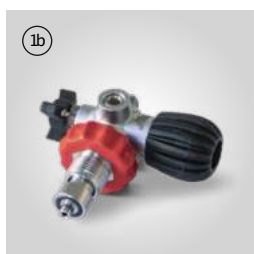

# Optional

- 1 Remote filling panel  
Single pressure 4 filling connections DIN 232

---

- 2 Remote filling panel  
Single pressure 4 filling connections DIN 300

---

- 3 Remote filling panel  
Double pressure 2 DIN 232 + 2 DIN 300

---

- 4 Remote filling panel con rubinetti a leva Pressione singola 4 INT + 4 DIN 232 + 4 DIN 300

---

- 5 Remote filling panel con rubinetti a leva Pressione doppia 2 INT + 1 DIN 232 + 1 DIN 300

---

- 6 Filling connection with gauge QR 232 bar

---

- 7 Filling connection with gauge QR 300 bar

---

- 8 DIN/INT adapter

---

- 9 Filling connection QR/INT

---

- 10 Presec, filter control system

---

- 11 SAM sensors CO + CO2 + H2O  
Available in version with VOC.

---

- 12 Tornado refrigerator - Dryer  
Available in 350 bar or 420 bar versions.

---

- 13 Filling hose. Available: 1,5m - 2,0 m  
3,0 m - 4,0 m - 5,0 m - 8,0 m - 10,0 m

---

- 14 Stainless steel frame

---







## Dimensions

Width 90,5 cm (35.6")  
 Depth 105,2 cm (60.2")  
 Height 153 cm (41.4")

## Dry weight

OPEN 450 EM 356 kg (784 lb)  
 OPEN 450 ET 356 kg (784 lb)  
 OPEN 550 ET 361 kg (796 lb)

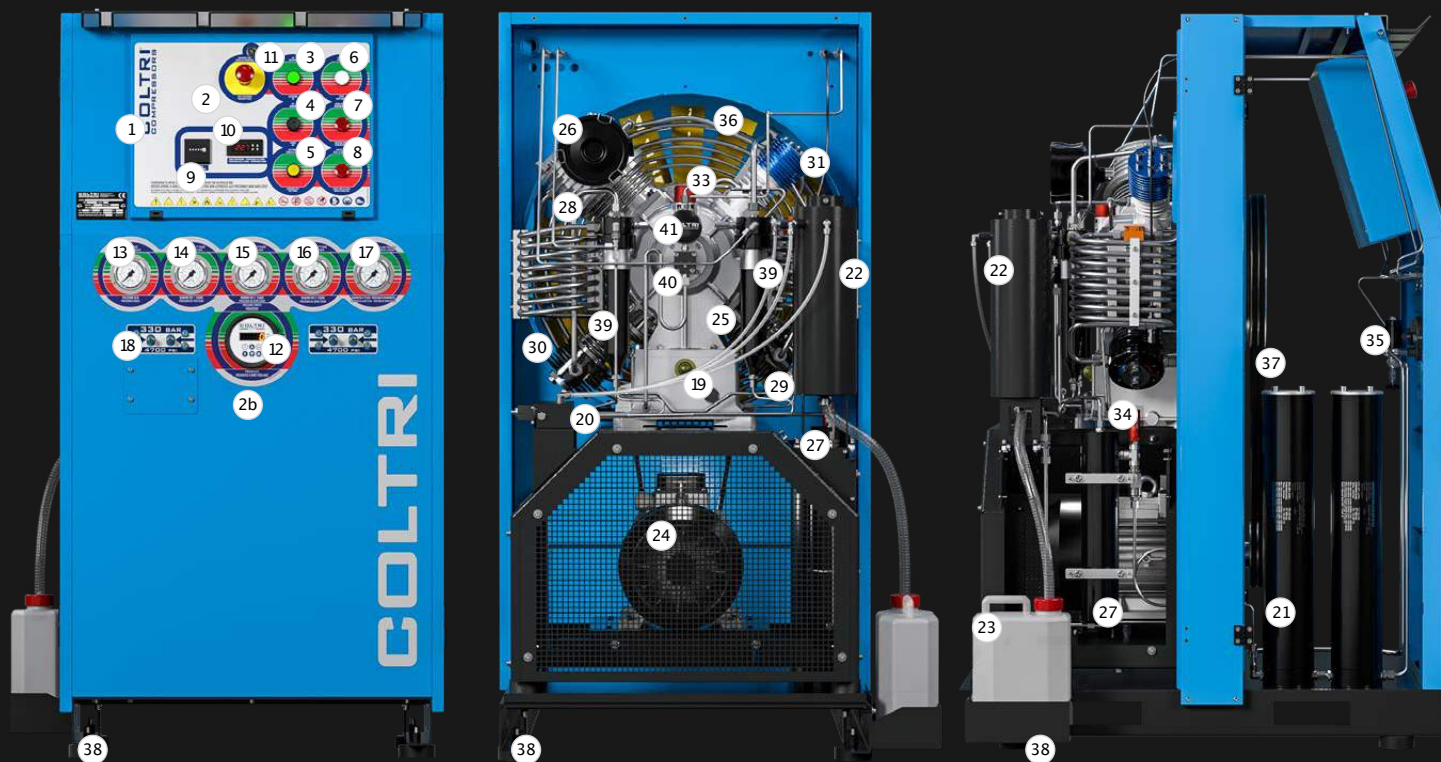
OPEN 650 ET 365 kg (804 lb)  
 OPEN 760 ET 373 kg (943 lb)



## Machine parts

- |   |  |                          |
|---|--|--------------------------|
| 1 Frame                                       | 14 1st stage pressure gauge                    | 28 1st stage             |
| 2 Control panel                               | 15 2nd stage pressure gauge                    | 29 2nd stage             |
| 3 ON pushbutton                               | 16 3rd stage pressure gauge                    | 30 3rd stage             |
| 4 Stop pushbutton                             | 17 4th stage pressure gauge / working pressure | 31 4th stage             |
| 5 Condensate discharge pushbutton             | 18 Refill hoses connection                     | 32 Monoblock             |
| 6 Power indicator light                       | 19 Oil level                                   | 33 Oil filler plug       |
| 7 Direction of rotation indicator light       | 20 Oil discharge valves                        | 34 Safety valve          |
| 8 Oil level warning light                     | 21 Purification system                         | 35 Maintenance valve     |
| 9 Hour counter                                | 22 Condensate collection container             | 36 Cooling fan           |
| 10 Cabinet interior / cooling air temperature | 23 Condensate collection tank                  | 37 Belt                  |
| 11 Emergency pushbutton                       | 24 Electric motor                              | 38 Anti-vibration device |
| 12 Automatic shutdown pressure switch         | 25 Pumping unit                                | 39 Condensate separator  |
| 13 Oil pressure gauge                         | 26 Air filter                                  | 40 Oil pump              |
|   | 27 Final condensate separator                  | 41 Oil filter            |

Heavy Duty line

# Silent

Electric

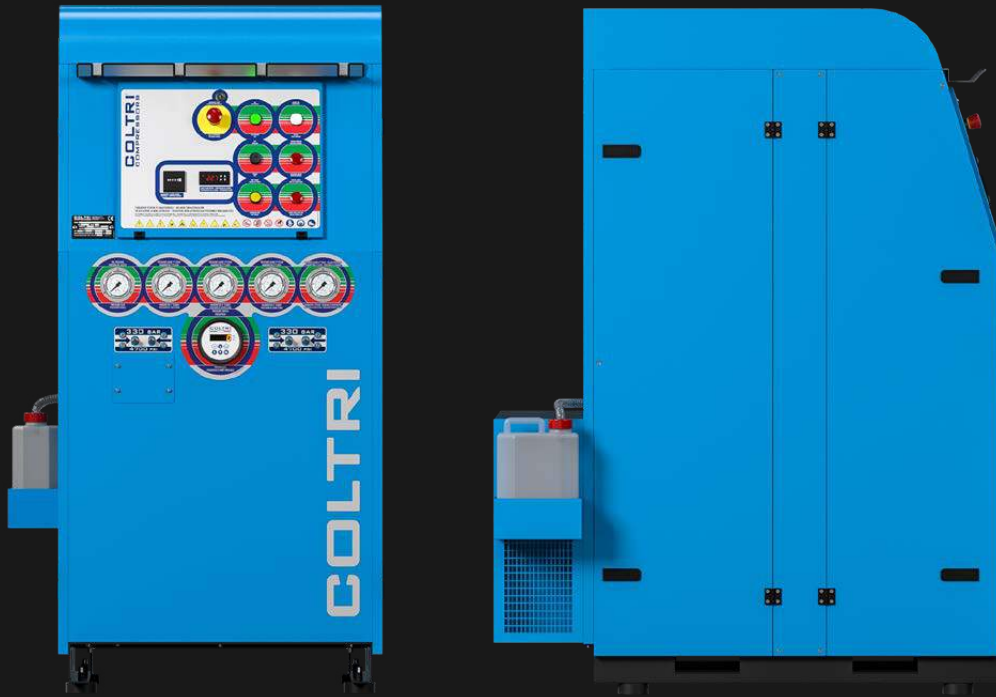

Silent 450 EM

Silent 450 ET

Silent 550 ET

Silent 650 ET

Silent 750 ET

Charging rate

450 l/min

450 l/min

550 l/min

650 l/min

750 l/min

Refill time<sup>1</sup>

4.30 min

4.30 min

4 min

3 min

2.40 min

Engine power

7,5 kW

Single-phase electric

7,5 kW

Three-phase electric

9 kW

Three-phase electric

11 kW

Three-phase electric

15 kW

Three-phase electric

<sup>1</sup> Filling time 10l empty cylinder -0/200 bar (tolerance ±5%)

# What you don't feel is his greatest performance.

The SILENT model reaches new heights in terms of soundproofing, falling below the 70 dB operating threshold. Built to meet the demands of intensive use when large refill capacities are required, it has 4 front filling connections with high pressure hoses and an intuitive control panel. It also has an electric motor and powerful pumping units. For longer filter life, we recommend the Tornado high pressure dryer. Available option: Presec system for filter saturation control or the SAM system for multigas analysis and remote charging panel.

Working pressure from 232 to 420 bar

## Standard equipment

1	2 filling connections to choose between (1a) DIN 232, (1b) DIN 300 o (1c) INT/YOKE 232 bar	8	Phase controller that prohibits reverse rotation
2	2 filling hoses of 1.2 m length	9	Electronic pressure switch with automatic switch-off
3	Pressure maintaining valve	10	Oil level auto cut off
4	Interstage control gauges	11	Oil pump
5	Double filtering system Hyperfilter certified PED	12	Auto-drain Condensate System with condensate collection tank
6	Cabin temperature with automatic switch-off	13	Frame color Blue RAL 5015
7	Automatic condensate drain		

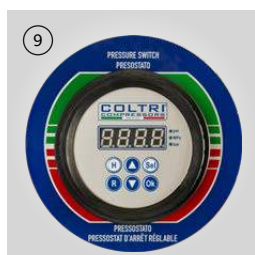
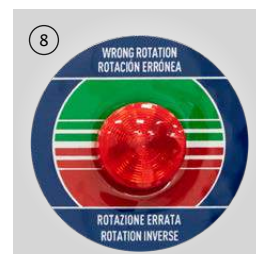
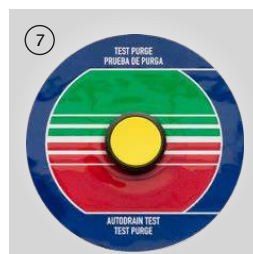
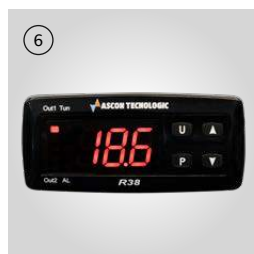
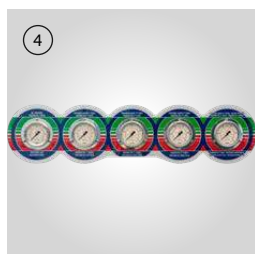
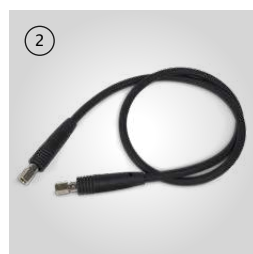
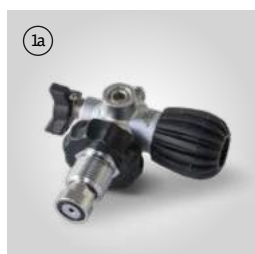

# Optional

- 1 Remote filling panel  
Single pressure 4 filling connections DIN 232

---

- 2 Remote filling panel  
Single pressure 4 filling connections DIN 300

---

- 3 Remote filling panel  
Double pressure 2 DIN 232 + 2 DIN 300

---

- 4 Remote filling panel con rubinetti a leva Pressione  
singola 4 INT + 4 DIN 232 + 4 DIN 300

---

- 5 Remote filling panel con rubinetti a leva Pressione  
doppia 2 INT + 1 DIN 232 + 1 DIN 300

---

- 6 Filling connection with gauge QR 232 bar

---

- 7 Filling connection with gauge QR 300 bar

---

- 8 DIN/INT adapter

---

- 9 Filling connection QR/INT

---

- 10 Presec, filter control system

---

- 11 SAM sensors CO + CO2 + H2O  
Available in version with VOC.

---

- 12 Tornado refrigerator - Dryer  
Available in 350 bar or 420 bar versions.

---

- 13 Filling hose. Available: 1,5m - 2,0 m  
3,0 m - 4,0 m - 5,0 m - 8,0 m - 10,0 m

---

- 14 Stainless steel frame

---







## Dimensions

Width 93,5 cm (36.8")  
 Depth 130 cm (51.3")  
 Height 173,5cm (68.3")

## Dry weight

SILENT 450 EM 446 kg (983 lb)  
 SILENT 450 ET 446 kg (983 lb)  
 SILENT 550 ET 451kg (994 lb)

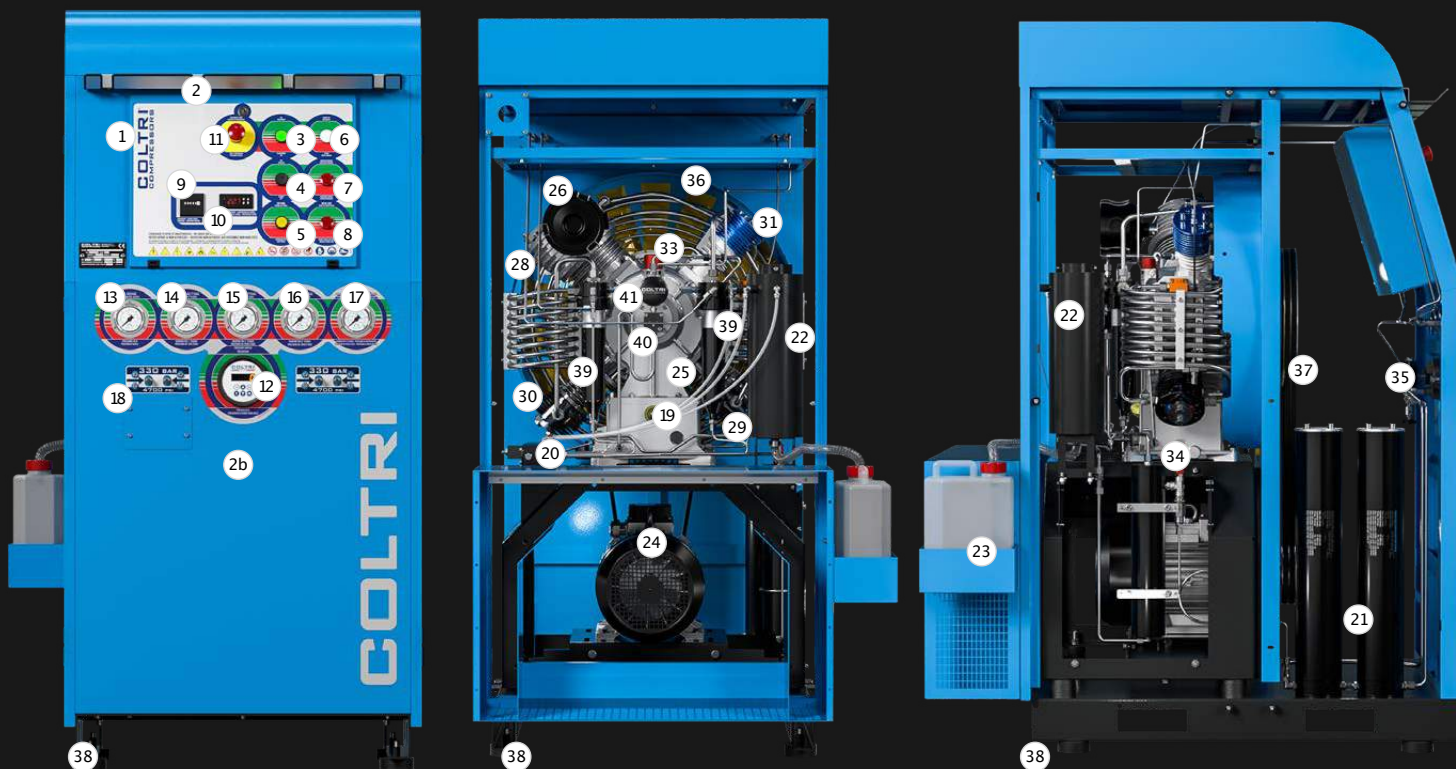
SILENT 650 ET 455 kg (1.003lb)  
 SILENT 760 ET 463 kg (1.020lb)



## Machine parts

- |   |  |                          |
|---|--|--------------------------|
| 1 Frame                                       | 14 1st stage pressure gauge                    | 28 1st stage             |
| 2 Control panel                               | 15 2nd stage pressure gauge                    | 29 2nd stage             |
| 3 ON pushbutton                               | 16 3rd stage pressure gauge                    | 30 3rd stage             |
| 4 Stop pushbutton                             | 17 4th stage pressure gauge / working pressure | 31 4th stage             |
| 5 Condensate discharge pushbutton             | 18 Refill hoses connection                     | 32 Monoblock             |
| 6 Power indicator light                       | 19 Oil level                                   | 33 Oil filler plug       |
| 7 Direction of rotation indicator light       | 20 Oil discharge valves                        | 34 Safety valve          |
| 8 Oil level warning light                     | 21 Purification system                         | 35 Maintenance valve     |
| 9 Hour counter                                | 22 Condensate collection container             | 36 Cooling fan           |
| 10 Cabinet interior / cooling air temperature | 23 Condensate collection tank                  | 37 Belt                  |
| 11 Emergency pushbutton                       | 24 Electric motor                              | 38 Anti-vibration device |
| 12 Automatic shutdown pressure switch         | 25 Pumping unit                                | 39 Condensate separator  |
| 13 Oil pressure gauge                         | 26 Air filter                                  | 40 Oil pump              |
|   | 27 Final condensate separator                  | 41 Oil filter            |

# Purification system

## Purification system MAXIFILTER

Used on Efficient line models.

MAXIFILTER polypropylene cartridge repackable or disposable

Purification system	Maxifilter
Operating pressure (Standard)	232 bar / 330 bar / 360 bar
Operating pressure max. (PS)	420 bar
Processable air capacity (air inlet temperature in the filter 20° C at 300 bar) <sup>1</sup>	890 m <sup>3</sup>

<sup>1</sup>When using a filter cartridge without HOPCALITE CO CATALYST.

When using a cartridge with CO-removal, the processable air capacity is reduced by ca. 20%.



## Separator system

Used on Efficient line models.

- Interstage separator after 2nd stage ,stainless steel AISI 316.
- Final separator for the removal of oil/water condensate.
- Final safety valve, fitted to separator housing.
- Pressure maintaining/nonreturn valve, fitted to filter bracket.

Contamination	Maximum content as per DIN EN 12021:2014	Air quality*
H <sub>2</sub> O	25 mg/m <sup>3</sup>	≤ 10 mg/m <sup>3</sup>
CO	5 ppm(v)	≤ 4
CO <sub>2</sub>	500 ppm(v)	≤ 500
Oil	0,5 mg/m <sup>3</sup>	≤ 0,5 mg/m <sup>3</sup>

\* Measured at our facility using ASCO HORA 160 ANALYZER.

<sup>1</sup> Only with special filter cartridge with HOPCALITE CO CATALYST. and up to a maximum concentration of 25 ppm CO in intake air. The compressed clean breathing air then contains a maximum of 5 ppm CO.

<sup>2</sup> The level of CO<sub>2</sub> in the intake air must not exceed the maximum level of CO<sub>2</sub> as per EN 12021:2014

<sup>3</sup> Reported values exceed ISO 8573-1 standards.

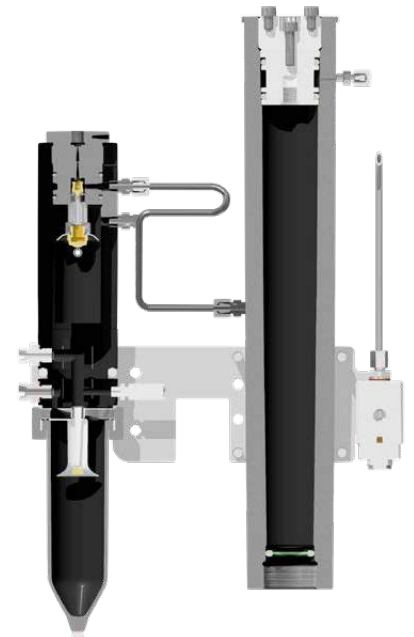

# Purificationsystem HYPERFILTER

Used on Prime Line and Heavy Duty Line models.

DOUBLE HYPERFILTER regenerable or disposable cartridge

Purification system	Hyperfilter x 2
Operating pressure (Standard)	250 bar / 330 bar / 360 bar
Operating pressure max. (PS)	420 bar
Processable air capacity (air inlet temperature in the filter 20° C at 300 bar) <sup>1</sup>	3.050 m <sup>3</sup>

<sup>1</sup>When using a filter cartridge without HOPCALITE CO CATALYST.

When using a cartridge with CO-removal, the processable air capacity is reduced by ca. 20%.

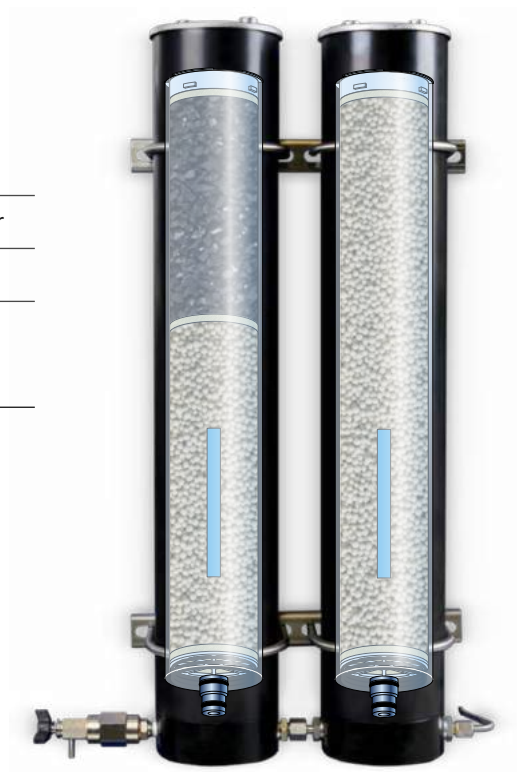

# Separator system

Used on TPS Prime Line models.

- Interstage separator after 2nd stage, forged and anodized aluminum.
- Double final separator for removal of oil/water condensate
- Final safety valve, mounted on the separator housing
- Pressure maintenance valve /non-returnvalve

Contamination	Maximum content as per DIN EN 12021:2014	Air quality*
H <sub>2</sub> O	25 mg/m <sup>3</sup>	≤ 10 mg/m <sup>3</sup>
CO	5 ppm(v)	≤ 4
CO <sub>2</sub>	500 ppm(v)	≤ 500
Oil	0,5 mg/m <sup>3</sup>	≤ 0,5 mg/m <sup>3</sup>

\* Measured at our facility using ASCO HORA 160ANALYZER.

<sup>1</sup> Only with special filter cartridge with HOPCALITE CO CATALYST. and up to a maximum concentration of 25 ppm CO in intake air.

The compressed clean breathing air then contains a maximum of 5 ppm CO.

<sup>2</sup> The level of CO<sub>2</sub> in the intake air must not exceed the maximum level of CO<sub>2</sub> as per EN 12021:2014

<sup>3</sup> Reported values exceed ISO 8573-1 standards.

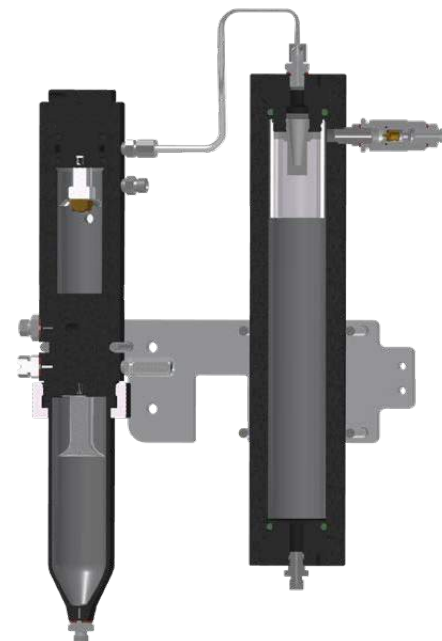

## MAXIFILTER cartridges

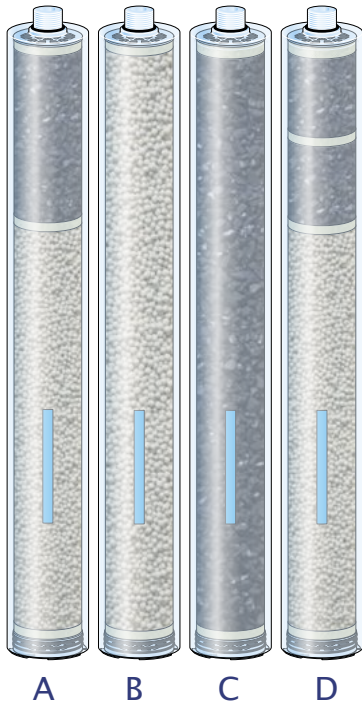

- A with molecular sieve and activated carbon
- B with molecular sieve
- C with activated carbon
- D with molecular sieve, activated carbon and CO-catalyst

## HYPERFILTER cartridges

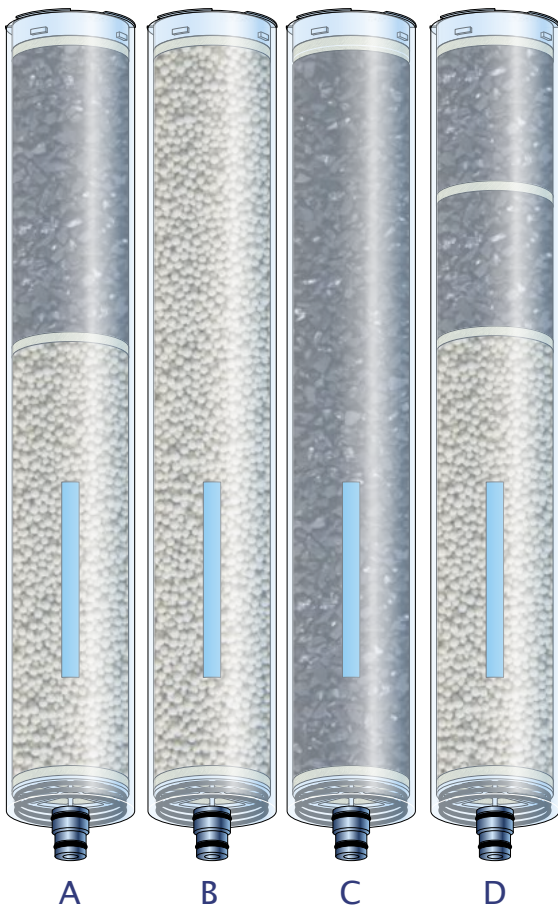

- A with molecular sieve and activated carbon
- B with molecular sieve
- C with activated carbon
- D with molecular sieve, activated carbon and CO-catalyst



## Synthetic Coltri Oil ST 755

A fully synthetic oil specifically developed for long lasting lubrication of process gas compressors and especially for breathing air. It provides outstanding performance in all types of compressors.



## Activated carbon

Activated carbon is a material containing mainly amorphous carbon. Due to its high specific area, activated carbon is able to hold many molecules of other substances within it, being able to accommodate these molecules on its large internal surface area.



## Molecular sieve

Molecular sieves are materials that can separate molecules based on size. This capability is based on the presence in the material of tiny pores of exact and uniform size, ranging in diameter from 3 to 10 Å depending on the material.



## CO catalyst

The trade name for a series of mixtures consisting primarily of copper and manganese oxides, used as catalysts for the conversion of carbon monoxide to carbon dioxide when exposed to oxygen in air at room temperature.



# Standard equipment

## Electromechanical pressure switch

Meter displays pressure in bar/psi. To be installed with existing Hyperfilter filter system on compressor.

Through the adjustment knob it allows to set the maximum pressure for automatic shutdown.



## Digital pressure switch

The instrument allows to visualize the pressure expressed in bar, psi or MPa.

Through the programming buttons it allows to set the intervention pressure of the relay contact (SPDT) and hysteresis. The settings are protected by passwords at 3 levels: manufacturer, customer and end user. The instrument also has the function of Hour Meter for hours of operation and anr. cycles of separator intervention, ensuring a general improvement of the operation of the recharge station over time and the longevity of its filters. Standard equipment for Prime and HD lines.



## According to EN 10204 Type 2.1

N.	Caratteristiche / Characteristics	Valori richiesti / requested values	Tolleranze / Tolerances	Strumento di controllo / Test equipment	Esito verifiche / Test Result
1	Setpoint alarm	300 bar	err.max 1,5% vfs	Elect. load 16V/10mA max	<b>OK</b>
2	Setpoint hysteresis	10 bar	err.max 1,5% vfs	Elect. load 16V/10mA max	<b>OK</b>
3	Range	0 – 400 bar	err.max 1,5% vfs	Pressure gauge cl. 0,25% vfs	<b>OK</b>
4	Process connection	G1/4"	Tab ISO228	Ring ISO228	<b>OK</b>

# Standard equipment

## Compressor control and automatic condensate drain system

- ON/OFF switch with motor protection switch.
- Optional: autostart at 60 bar hysteresis.
- Transformer.
- Pressure switch stops compressor at final pressure.
- Drainage of all separators between the individual stages and also of the final separator during compressor operation (standard drain interval every 15 minutes for a period of 6 seconds).
- Timer for automatic condensate drainage device.
- Integrated vacuum start-up (automatic drain when the unit is switched off).
- Condensate collection tank 5 liters, with silencer; capacity approx. 3 liters, for environmentally friendly disposal of condensate.
- Interstage pressure gauges display the operating pressure for the individual compression stages. This pressure information allows you to check the tightness of the valves (inlet and outlet) of each stage and quickly identify potential sources of failure.

The interstage pressure gauges are mounted in the compressor frame.





# Optional

## Tornado refrigerator – Dryer

Used on Heavy Duty and Super Silent TPS line.  
Cooler, dryer for high pressure compressed air.

### UP TO 3 TIMES LONGER FILTER SERVICE LIFE

- Higher air quality
- Less corrosion of mechanical parts
- Refilling of cylinders with constant percentage of humidity

The TORNADO refrigerator is an accessory for our recharge stations dedicated to professional use that operates between the separators and the filtering system. Available in 350 or 420 bar versions.

### HOW TORNADO WORKS

The incoming warm, moist air passes into the evaporator of this machine, inside which it cools. This allows the moisture to condense. Condensation is then easily removed from the separator, ensuring an overall improvement in the operation of the charging station over time and the longevity of its filters.





# Optional

## Presec. Filter control system

### Includes:

Filter cap with sensor + control unit + cartridge.

To be installed with the Hyperfilter filter system on compressor.

The Presec system is connected through a probe with the first filter cartridge and detects its saturation status transmitting to the indicator the relevant switching signals according to the status. If the filter cartridge is exhausted, the compressor is switched off and cannot be started until the cartridge is replaced.

The presec system displays 4 levels of cartridge saturation through 3 relays connected to 3 leds:

Stable green light (a):

- The system is operational; OK cartridge

Yellow light button (b):

- Pre-alarm; cartridge is running low and must be replaced soon.

Red light button (c):

- Alarm; remove cartridge, replace immediately.

Red light button (c):

- Alarm; filter cartridge is missing or filter system is interrupted; compressor shuts down and cannot be turned back on without inserting a new cartridge or discovering the source of the alarm.

While the yellow light is pulsing (b), the steady green light (a) will still be on because the filter cartridge will not be fully saturated.



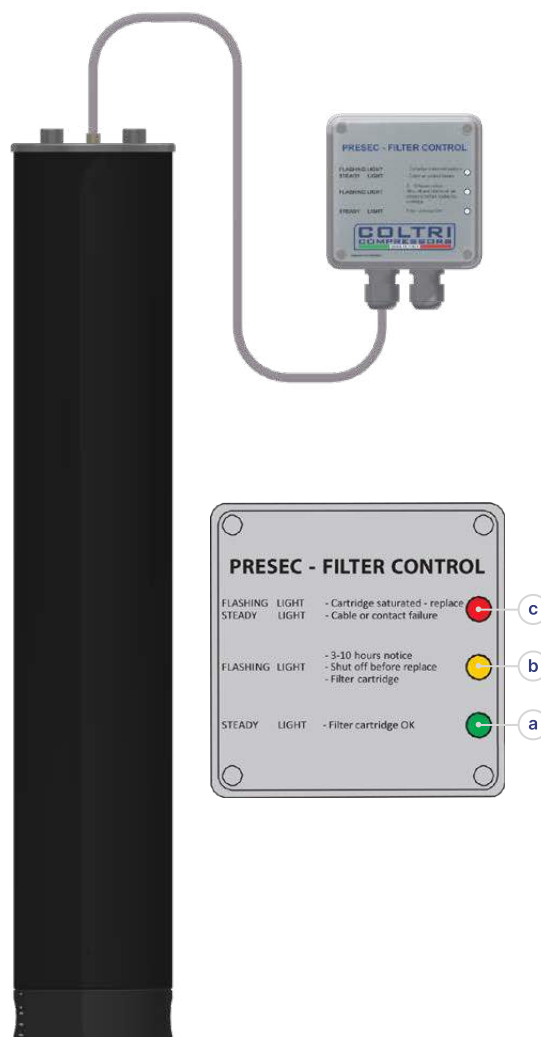





If no LED lights up, it means that the PRESEC lacks power or that the electrical system is faulty.



# Optional

## C-Monitor

Final filter monitoring system, oil change and technical interface.

The interface consists of an LCD display, a button  and two indicators (, ). The decimal points next to the digits are indicator lights to indicate alarms or warnings in progress. Each dot is associated with an explanatory icon (, , ). The icon  indicates an alarm condition while the symbol  indicates normal operation. Press the button  to scroll through the different functions of the menu. When pressed, the function is displayed and after two 2 seconds the corresponding data is displayed.

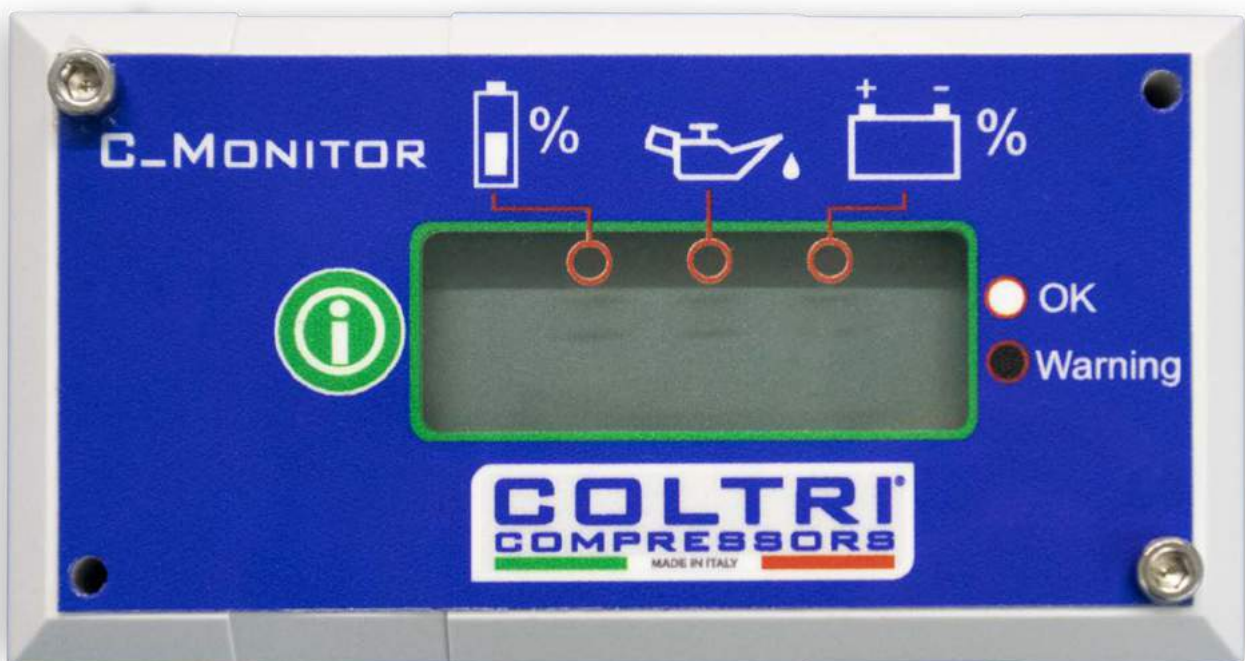

# Optional

## Multi-Gas Analysis System (SAM)

Scegliendo il SAM Sistema Analisi Multigas non è possibile installare anche il sistema Presec.

The Coltri Multi-Gas Analysis System is a measuring instrument capable of monitoring air quality. Its application includes continuous monitoring of environmental gases, hyperbaric chambers, safety, medical, air quality.

Available sensors:

- Oxygen O<sub>2</sub>
- Carbon dioxide CO<sub>2</sub>
- Carbon Monoxide CO
- Humidity H<sub>2</sub>O
- Gas Temperature
- VOC (Volatile Organic Compound)
- Helium in Air



### General specifications

Input voltage requirement	10–35 Vdc
Internal Battery	Rechargeable lithium-ion battery. One cell 1400 mAh Li ion 3.7 V
Sensors	Up to 6 sensors
Output	Acoustic alarm
Serial Connection	1 RS232 interface. Transmission speed up to 115000 baud, on request RS485 interface
Measurement resolution	Bipolar 24-bit A/D converter. Drift in automatic temperature compensation.
Conversion rate	10 ms
Sampling time	100 ms (min) for each channel
Signal measurement accuracy	0.1% Full scale $\pm 1/2$ LSB
Input device	Rotary knob with central push
Color Display	TFT 320 x 240 dot resolution, LED backlighting
Display light intensity	600 nits (cd/m <sup>2</sup> )
Memory	Micro SD card writer/reader
Microprocessor	Cortex M4

Nitrox line

# LP Rotary Silent 250



Oxygen percentage

---

32% O<sub>2</sub>

36% O<sub>2</sub>

38% O<sub>2</sub>

L/min.

---

315 l/min

235 l/min

200 l/min

Membrane type

---

Parker Enoxy SA 708 oxygen



# LP Rotary Silent 250

It consists of an industrial screw compressor that delivers air at a pressure of 10 bar to the Parker® membrane. The percentage of oxygen obtained at the outlet can be adjusted from 28% to 38% thanks to a valve accessible on the front side of the compressor. When connected to a compressor with pumping unit 315 (MCH 16), 32% Nitrox can be obtained up to a pressure of 232 bar. The oxygen analyzer allows to verify the correct percentage, adjusting it through the appropriate valve.

## Standard equipment

1 Electrical panel

2 Automatic condensate drain

3 2 Analyzers

4 Thermostat

5 1 Parker Enoxy SA 708 oxygen membrane

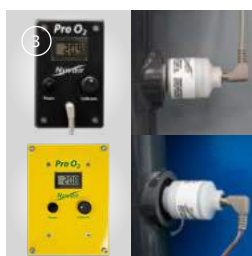

Nitrox line

# LP Rotary Silent 300



Oxygen percentage

---

32% O<sub>2</sub>

36% O<sub>2</sub>

40% O<sub>2</sub>

L/min.

---

600 l/min

380 l/min

300 l/min

Membrane type

---

Permea 230

# LP Rotary Silent 300

It consists of an industrial screw compressor that delivers air at a pressure of 12 bar to a membrane that separates nitrogen and oxygen up to a maximum percentage of 40% oxygen. The enriched air can be compressed to 232 bar in combination with a high pressure compressor. The percentage of oxygen obtained at the outlet can be adjusted from 22.4% to 40% thanks to a valve accessible directly on the top of the compressor. The oxygen analyzer allows to verify the correct percentage, adjusting it through the appropriate valve.

## Standard equipment

1 Electrical panel

2 Automatic condensate drain

3 2 Analyzers

4 Thermostat

5 1 Permea 230 membrane

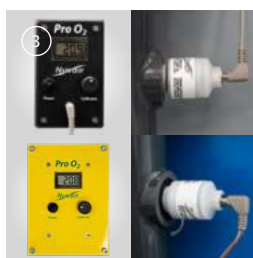

Nitrox line

# LP Rotary Silent 600



Oxygen percentage

---

32% O<sub>2</sub>

40% O<sub>2</sub>

L/min.

---

1.000 l/min

650 l/min

Membrane type

---

Double Permea 230



# LP Rotary Silent 600

It consists of an industrial screw compressor that delivers air at a pressure of 12 bar to a membrane that separates nitrogen and oxygen up to a maximum percentage of 40% oxygen. The enriched air can be compressed to 232 bar in combination with a high pressure compressor. The percentage of oxygen obtained at the outlet can be adjusted from 22.4% to 40% thanks to a valve accessible directly on the top of the compressor. The oxygen analyzer allows to verify the correct percentage, adjusting it through the appropriate valve.

## Standard equipment

1 Electrical panel

2 Automatic condensate drain

3 2 Analyzers

4 Thermostat

5 Double Membrane Permea 230

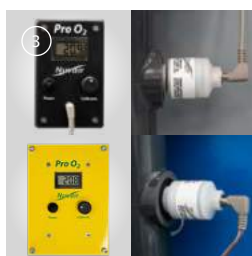

Fill containment cabinet

# Armor



Armor 2

Armor 4

Filling connection

DIN 300 bar

DIN 300 bar

Containment tank

Max Diameter 220 mm

Dimensions

60 x 73 x 104 cm

(W x D x H)

70 x 65 x 80 x 116 cm

(W x D x H1 x H2)

# Armor 2

Coltri explosion-proofbooths allow you to use the charging stations in total safety thanks to the taps, integrated hoses and pressure gauge.

# Armor 4

The version for multiple refills with hinged door is equipped not only with the standard equipment, but also with filling valves and pressure management.



## Standard equipment

- 
- 1 Filling hose DIN 300 bar
- 

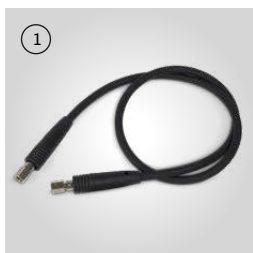

## Optional

- 
- 1 Filling connection DIN 232
- 
- 2 Filling connection DIN 300
- 

- 
- 3 DIN/INT adapter
- 
- 4 Filling connection INT/YOKE
- 

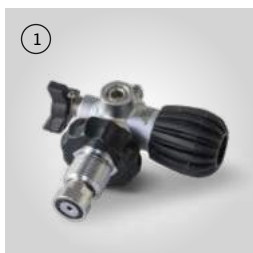

dystrybutor oraz autoryzowany serwis:

**SCUBA MISSION**  
Rafał Kowalewski

ul. Mazurska 7  
70-424 Szczecin - Poland

tel +48 91 4881787  
fax +48 91 4881787

[www.scubamission.pl](http://www.scubamission.pl)  
[info@scubamission.pl](mailto:info@scubamission.pl)



**EU Ecolabel:**  
PT/011/002



**COLTRI**  
THE ITALIAN COMPRESSOR